



## Franklin Home Power Installation Guide

Version 1.3.06

©2024 FranklinWH Energy Storage Inc. All rights reserved.

All information in this Manual is subject to the copyright and other intellectual property rights of FranklinWH Energy Storage Inc. This manual may not be modified, copied or reproduced, in whole or in part, without the prior written permission of FranklinWH Energy Storage Inc.

Please visit [FranklinWH Support](#) for the latest Franklin Home Power documents.

All brands and trademarks mentioned in this document are the property of their respective owners, and their use in this document does not imply the sponsorship or recognition of their products or services.

Please read this document carefully to ensure the best reliability of the product and your warranty eligibility. For further information about the warranty, please refer to the **FranklinWH Limited Warranty**.

This document is intended for use by professional installation and maintenance service providers only and no statements, information or recommendations in this document constitute any express or implied warranty.

---



Please read this document carefully before installing or using the Franklin Home Power equipment. Failure to follow any instructions or warnings in this document may result in damage to the equipment, personal electric shock, severe injury, or even death.

---

## Product Information

The Franklin Home Power (FHP) system is composed of aPower, aGate and other electrical components, and this document applies only to the following products: aPower X and aGate X.

FranklinWH Energy Storage Inc. ("FranklinWH") reserves the right to make any improvements to the product, and the contents in this document shall be subject to updates without further notification.

All images and pictures provided in this Manual are only for demonstration purposes and may differ in detail from the product, based on the product version.

---

## FCC Compliance

This equipment has been tested and found to comply with the limits for a Class B digital device, pursuant to part 15 of the FCC Rules. These limits are designed to provide reasonable protection against harmful interference in a residential installation. This equipment generates, uses and can radiate radio frequency energy and, if not installed and used in accordance with the instructions, may cause harmful interference to radio communications. However, there is no guarantee that interference will not occur in a particular installation. If this equipment does cause harmful interference to radio or television reception, which can be determined by turning the equipment off and on, the user is encouraged to try to correct the interference by one or more of the following measures:

- Reorient or relocate the receiving antenna.
- Increase the separation between the equipment and receiver.
- Connect the equipment into an outlet on a circuit different from that to which the receiver is connected.
- Consult the dealer or an experienced radio/TV technician for help.

MPE caution (if an FCC certified RF module is inserted in and the separation distance is indicated in the FCC grant of RF module).

To satisfy FCC / IC RF exposure requirements, a separation distance of 8 in. (20 cm) or more should be maintained between the antenna of this device and persons during device operation.

To ensure compliance, operations at closer than this distance is not recommended.

## Feedback

If you have any questions or comments, please send us an email at: [service@franklinwh.com](mailto:service@franklinwh.com)

## Disposal of Scrapped Products

Scrapped products (including their internal chemicals and electrical materials) should not be disposed of with household wastes. Please refer to your local laws and regulations regarding disposal.



---

---

## CONTENT

Safety Statements .....	1
Safety Symbols.....	1
Safety Instructions for Operation.....	2
Safety Instructions for Installation Site .....	5
Fire and Other Emergency Situations.....	7
Franklin Home Power System Overview .....	8
Whole-Home Backup System.....	8
Partial Backup System.....	9
Installation Preparations .....	10
Site Planning.....	10
Tools Needed .....	14
Items Provided by Installers.....	16
Unboxing .....	17
Unbox the aGate .....	17
Unbox the aPower .....	18
Installation .....	19
aGate Installation.....	19
Remove the door and inner panel from the aGate .....	19
Prepare aGate cable inlets .....	21
Enlarging or Drilling New Holes (if necessary).....	22
Install optional module(s) .....	22
Install breakers as needed .....	22
Mount the aGate on a wall.....	24
aPower Installation .....	26
Mount the bracket .....	26
Drill conduit entry holes on the wall (if needed) .....	29
Mount the aPower in the bracket .....	30

---

---

Level the floor mounted aPower .....	31
Install a Combiner Box (if needed) .....	31
System Wiring .....	32
Install Electrical Conduit on the aPower Wiring Compartment .....	32
Communications Wiring .....	34
Electrical Wiring .....	40
Connecting the solar inverter to the aGate .....	41
Connecting the backup panel to the aGate.....	41
Connecting the grid supply to the aGate .....	42
Connecting aPower(s) to the aGate .....	43
Install Optional Emergency Power Off (EPO) Switch .....	47
Completing Installation .....	49
Re-Install the aPower Wiring Compartment Cover and Install Grilles.....	49
Re-Install the aGate Door and Inner Panel.....	50
Commissioning and Acceptance .....	51
Appendix 1: Allowed Breakers .....	51
Appendix 2: NEC AC Disconnect Labeling Requirements .....	54
Appendix 3: Datasheet .....	54







---

## Safety Statements











This Guide includes important information about the Franklin Home Power system. Please read this Guide carefully before installation, maintenance, or use. Failure to follow any instruction in this Guide may lead to risks of equipment damage, electric shock, severe personal injury and even death, and may also void the warranty ([FranklinWH Support](#)).













The DANGER, WARNING, and NOTE alerts are supplemental to the safety instructions and are not exhaustive.





## Safety Symbols

	<b>DANGER:</b> This indicates a hazardous situation, which if not avoided, could result in serious injury or death.
	<b>DANGER:</b> There are fire risks in the battery packs.
	<b>WARNING:</b> This indicates a situation where failure to follow instructions may be a safety hazard or cause equipment malfunction. Use extreme caution and follow instructions carefully.
	<b>NOTE:</b> This indicates information important for optimal system operation. Follow instructions carefully.
	<b>PROTECTIVE GROUNDING TERMINAL:</b> This indicates the position of grounding connection on the equipment.
	<b>WAIT TIME:</b> It means there are electric shock risks inside the equipment, please wait 5 minutes before proceeding.
	<b>ELECTRONIC DEVICE: DO NOT THROW AWAY.</b> Scrapped electronic products and batteries cannot be disposed of together with household wastes. Please consult your local laws and regulations for further information.











## Safety Instructions for Operation





	<b>DANGER:</b> The installation, wiring, maintenance, transportation, and handling of each aGate and aPower should follow local laws, regulations and standards, and the Safety Instructions in this Guide serve as supplementation to the laws, regulations, and standards.
	<b>DANGER:</b> Before any electrical operation starts, please turn off the grid power supply switch, generator input switch, the solar input switch, the load switch, and lock the switches. If the switches cannot be locked, please lock the distribution box where the switches are installed. A warning sign, <b>Out of Operation</b> , or <b>Do NOT Turn On</b> , should be hung.
	<b>DANGER:</b> Both aPower and aGate are electrical equipment, and improper operation may lead to electric shock, energy hazards, or chemical hazards. Please do NOT open the cabinet or disassemble without express direction from the FranklinWH service team.
	<b>DANGER:</b> Only FranklinWH certified and qualified technicians can install, maintain, or replace aGate and aPower equipment or wiring. They must wear personal protective equipment (PPE) during operation.
	<b>DANGER:</b> It is strictly forbidden to work on or operate the system alone. For safety, make sure that there is someone around you who can help.
	<b>DANGER:</b> It is strictly forbidden to install, maintain, or handle the system outdoors during bad weather conditions, such as lightning, thunder, rain, snow, or strong winds.
	<b>DANGER:</b> In case of a battery fire, please take actions as instructed in the <i>Safety Data Sheet</i> .
	<b>DANGER:</b> The aPower must be carefully handled and installed using lifting equipment to avoid injury to installers or the aPower.
	<b>DANGER:</b> During the transport and handling of aGate and aPower units, extreme care is required to avoid dropping, bumping, stomping, or inverting the equipment. To prevent potential damage, please keep all aPower units in their packaging until ready to install.
	<b>DANGER:</b> During use, storage, and transport, ensure that the ambient temperature of an aPower does not exceed 122 °F (50 °C), that it is not near flammables, and that the cooling system and vents are not blocked.
	<b>DANGER:</b> Do not attempt to take apart, repair and/or modify an aGate or aPower without the authorization of FranklinWH. And it is prohibited to open the battery pack chamber in any situation. Otherwise, it may lead to safety hazards and void your warranty.

	<b>DANGER:</b> To prevent misoperation, ensure that the upstream and downstream switches are disconnected and padlocked during installation or maintenance.
	<b>DANGER:</b> If an aPower or aGate is found damaged (except for minor defects in exterior painting) after it is unboxed or malfunctioning on installation, please do NOT operate it and contact your after-sales service provider for support.
	<b>DANGER:</b> Before any installation and commissioning of an aPower, please keep the round switch button on the right part of aPower off (extended, flush with the case) and prevent the ON/OFF switch from being operated by mistake.
	<b>DANGER:</b> If the aPower battery is leaking electrolyte, smoking, or catching fire, if it is safe to do so, please disconnect the AC power from the FHP system, and turn off the aPower switch to stop charging and discharging the battery.
	<b>DANGER:</b> The installation of the FHP system must comply with all applicable requirements of NFPA855.
	<b>DANGER:</b> Both electric connection and electric isolation need to comply with the local standards and National Electric Codes (NEC), ANSI/NFPA 70 or Canadian Standards Association CSA C22.1.
	<b>DANGER:</b> The installer needs to provide suitable conduits and cables, and complete the installation process in accordance with the local regulations and UL514B.
	<b>WARNING:</b> For maintenance purposes, do NOT use any parts or fittings that are not listed in this Guide or that are purchased from any source other than FranklinWH or its recognized dealers.
	<b>WARNING:</b> Measures should be taken to prevent foreign objects from entering any aPower or aGate.
	<b>WARNING:</b> Do NOT use paint on any part of an aPower or aGate, whether internal or external, especially on the protective cover except for exterior paint that has been worn out or damaged in the transportation, installation, or maintenance process. The damaged part can be repaired with paint or topcoat of the same color.
	<b>WARNING:</b> Do NOT connect an aPower directly to the solar inverter.
	<b>WARNING:</b> Before installation, do not store an aPower on site for more than one month. After installation, do not turn on the aPower before connecting the PV and grid, otherwise the battery will be depleted due to a long period of time without charging.

	<b>WARNING:</b> FHP system is composed of an aGate, and one or more aPower units, and other electrical components which cannot be used separately.
	<b>WARNING:</b> An aPower may only be connected to the aPower breaker on the aGate or to the backup load terminals on aGate.
	<b>WARNING:</b> The inputs from grid and generators may only be connected to the respective reserved terminals on the aGate.
	<b>WARNING:</b> The operation of the FHP system requires an Internet connection. Extended offline operation may result in a voided warranty. Please refer to <a href="#"><i>FranklinWH Support</i></a> for information.

## Safety Instructions for Installation Site

	<b>DANGER:</b> The installation site of aPower and aGate units should be protected from access by children, or additional protective measures should be taken to protect the FranklinWH equipment from misoperation and contact by children.
	<b>DANGER:</b> The installation site of aPower and aGate units should be kept away from heating devices, or any source of heat and/or fire.
	<b>DANGER:</b> The aPower and aGate installation area should be protected from flooding and standing water.
	<b>DANGER:</b> The aPower and aGate installation area should be away from flammable and explosive materials.
	<b>DANGER:</b> The installation site for aPower should have a fire detection and protection systems that meets the local building and fire codes. Temperature detectors and fire detectors must be used in the vicinity of the installation zone and must be connected to the family fire control system.
	<b>WARNING:</b> The aPower and aGate installation area should be well-ventilated to maintain the ambient temperature within -4 °F–122 °F (-20 °C–50 °C) and the relative humidity between 5 % and 95 %. The altitude should be lower than 9,843 ft (3,000 m).
	<b>WARNING:</b> Before the installation starts, engineers should check and locate the embedded electric wires and water pipes to avoid potential property damage and personal injury during the installation process.
	<b>WARNING:</b> aPower units may be installed on the floor or on walls, a floor installation is recommended. If wall-mounted, the wall should be able to provide sufficient bearing capacity.
	<b>WARNING:</b> The aPower and aGate installation area should be protected from dust and smoke.
	<b>WARNING:</b> The aPower and aGate installation site should be protected from direct exposure to sunshine, rain, and snow.
	<b>WARNING:</b> The aPower and aGate installation site should have no water source above it or in the vicinity, including water pipes, shower, faucet, and containers of liquids.

	<b>WARNING:</b> The installation site should be properly leveled and hardened if the aPower is floor mounted. If there is grass nearby, a layer of cement or slab stone must be placed on the projection area around the equipment to prevent grass growth and protect the equipment.
	<b>WARNING:</b> Do NOT clean aPower and aGate units with cleaning agents or expose them to flammable or irritant chemicals or their vapors.
	<b>WARNING:</b> The noise factor (< 45 dB) must be considered when selecting the installation site for each aPower. Selection of the site must involve consent of residents.
	<b>WARNING:</b> It is required that internet connectivity is provided at the aGate installation site. A hardwired connection is more reliable but Wifi and 4G connections are possible.

## Fire and Other Emergency Situations

### Fire:

- Shut off the aPower breaker on the aGate, if it is safe to do so.
- Evacuate to a safe area.
- Contact 911 as soon as it is safe to do so.
- Use approved fire extinguishing devices, if it is safe to do so.

### Flood:

- Shut off the aPower breaker on the aGate if it is safe to do so.
- If the wiring sections of aPower or aGate are submerged, please stay away from the water. Electric leakage may result in electric shock.
- Drain the water to protect the system if it is safe and possible.
- If water rises to the battery level, please call your installers for inspection. If water level is below the battery chamber, please allow the site to completely dry.

### Abnormal noise, odor, or smoke:

- Shut off the aPower breaker on the aGate, if it is safe to do so.
- Check and ensure your aPower is well ventilated and not blocked.
- Keep the installation site well ventilated.
- Call your after-sales service for support.

## Franklin Home Power System Overview

FranklinWH is a whole-home energy solution suitable for residential use. The two key components are the aGate, an intelligent power management unit for whole home power control, and the aPower, an energy storage battery unit with built in battery management system (BMS) and inverter. Users can monitor and operate their systems remotely via the FranklinWH App. With AC coupling and energy management technologies, the Franklin Home Power (FHP) system provides a reliable household backup and load control solution for homes.

The FHP system backup options include whole-home backup and partial backup. Load selection for different options must be completed during the system design phase.

The aPower stores energy from the grid, solar systems, and generators, and can power the home during grid outages, during peak rate periods, or at night (for solar self-generation).

## Whole-Home Backup System

In the whole-home backup system, all household loads, except for Smart Circuit loads, are connected via the Main Panel to the backup port of the aGate. If the grid fails, the FHP system power can support all household energy loads.

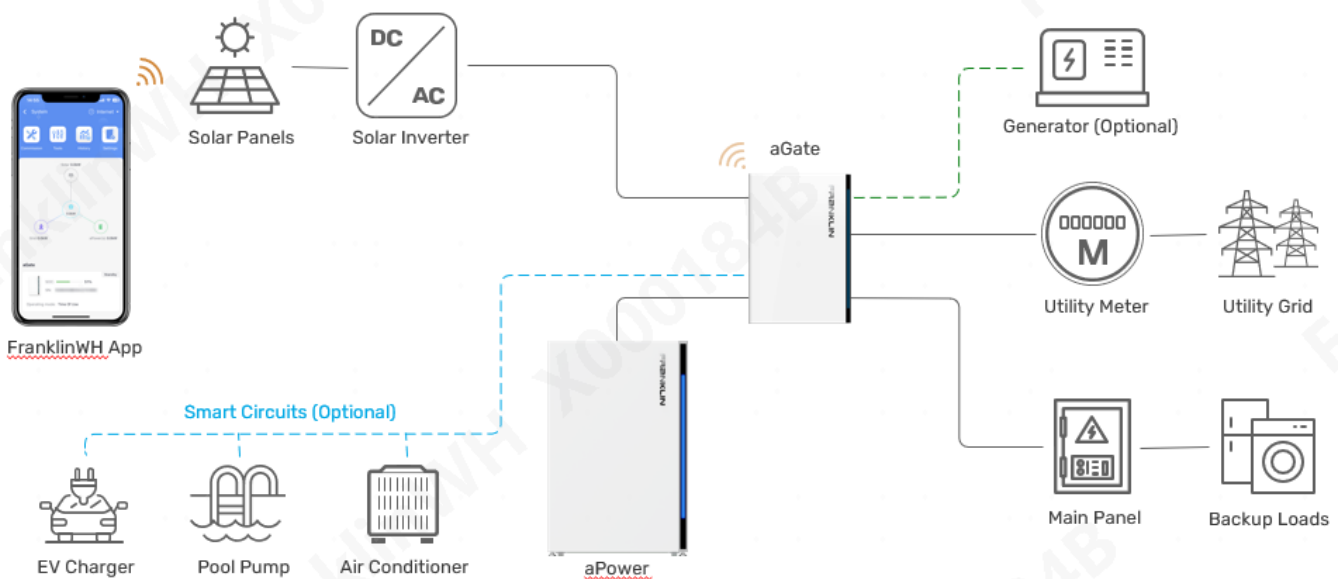

## Partial Backup System

If you select a partial backup configuration, you need to identify backup loads during system configuration. Connect the backup loads (except for the Smart Circuit loads) to the backup port of the aGate, and connect the non-backup loads to the non-backup port of the aGate. If the grid fails, the FHP system will only power the backup loads during an outage.

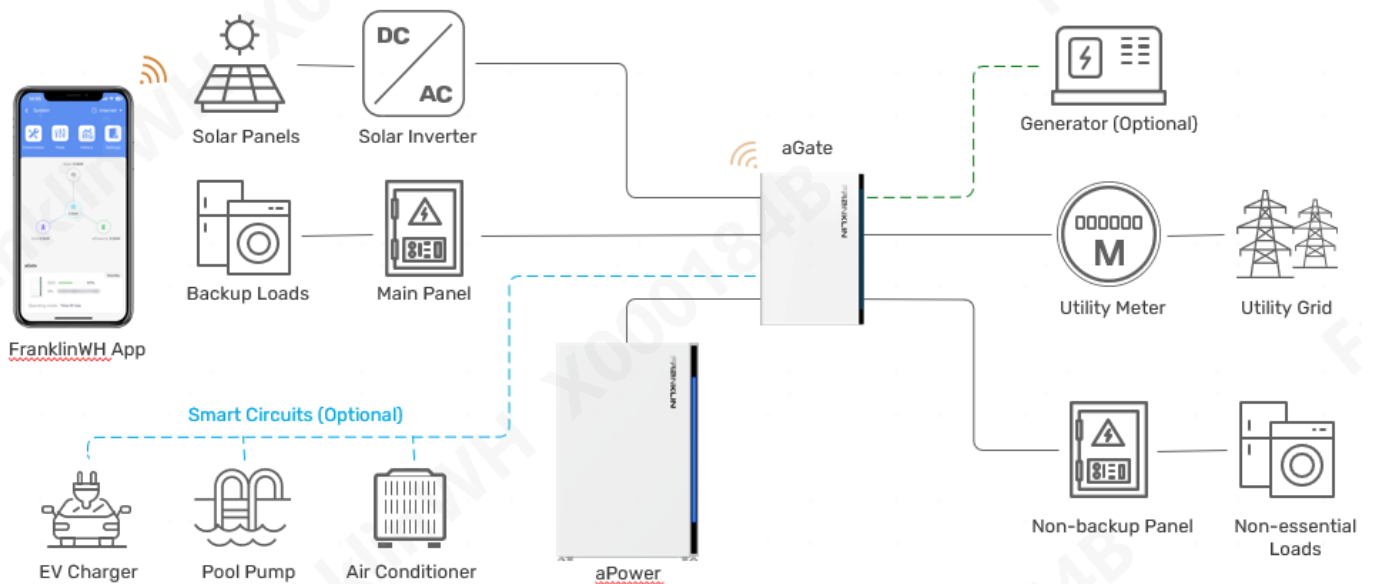

# Installation Preparations

## Site Planning

### 1. Plan installation position



**NOTE:** The selection of installation location must avoid water and power conduits. Refer to all applicable local codes and standards.

In Canada, it's required to install the system indoors to maintain the specified operation temperatures.

- 1) Choose a mounting location that can bear the weight of the aGate, aPower and bracket.
- 2) The details below are general guidelines for spacing and may not be applicable. Please consult with your local AHJ or Utility before finalizing the spacing.

#### aGate

There should be at least 6 in. (0.15 m) of clearance from the top of aGate to the ceiling, and 36 in. (0.91 m) of clearance in front of the aGate.

The recommended distance between the bottom of aGate and the ground is 48 in. (1.2 m), not exceeding 52 in. (1.3 m) i.e., the maximum distance between the power switch button on the aGate and the ground shall not exceed 79 in. (2 m) per the NEC requirements.

#### aPower

There should be a minimum clearance of 6 in. (0.15 m) from the top of aPower to the ceiling.

For the aPower mounted on a wall or floor, the maximum distance between the bottom of the aPower and the ground shall be  $\leq 42$  in. (1.1 m) i.e., **the maximum distance between the aPower switch button and the ground shall not exceed 79 in. (2 m) per NEC 404.8(A) requirements.**

For multiple aPowers installed at the same height, the minimum separation between adjacent aPower units or side walls should be more than 4 in. (0.1 m).

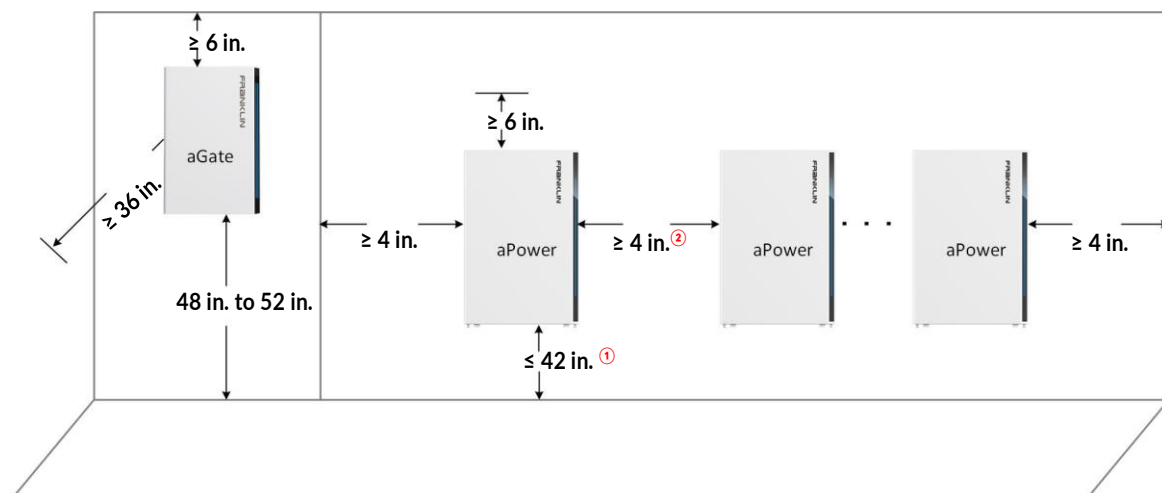

① NEC 408.4(A) requires the aPower switch to be no more than 79 in. (2m) from the ground.

② 4 in. (0.1 m) between adjacent aPower units or side walls is UL9540A required clearance. Refer to all applicable local codes and standards.

- 3) The FHP system requires an internet connection. All signal transfers between aPower and aGate units, the generator, and the router are realized by a CAN bus, network cables or other signal transmission cables. Long distances will likely adversely affect the quality and speed of communications, negatively impacting equipment operations. Recommended maximum cable lengths listed below.

Connection	Maximum cable length
aPower to aGate	98.4 ft (30 m)
Split CT to aGate	49.2 ft (15 m)

**2. Plan the positions of equipment inputs and outputs**

- 1) aPower inputs and outputs

The positions of inputs and outputs on an aPower are as shown below. The following scenarios offer variations on the cable inlets and outlets of an aPower to accommodate variations in the existing residential wiring layout.

The cable inlets on the wiring compartment of an aPower are 1.38 in. (35 mm) and 1.12 in. (28.5 mm) in diameter. The pull boxes have thread size of NPT 1" and NPT 3/4" .

**Scenario 1:** The electrical conduits and aPower share the same side of the wall.

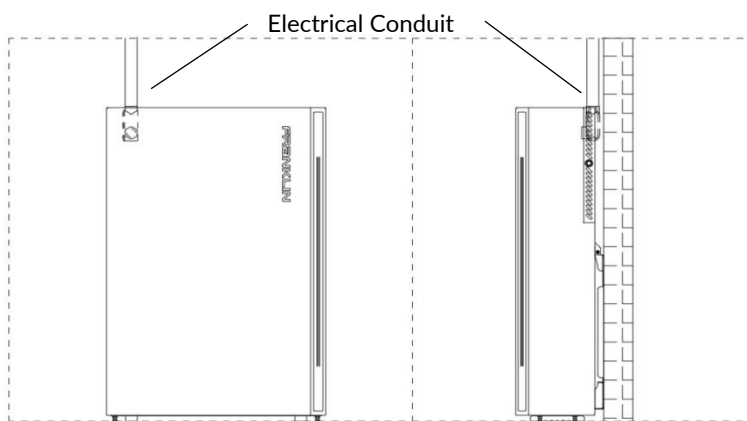

Gasketed pull boxes and sealing rings must be used to ensure the tightness of the wiring compartment.

**Scenario 2:** The cables will connect to the aPower from inside or through the electrical conduits through the wall.

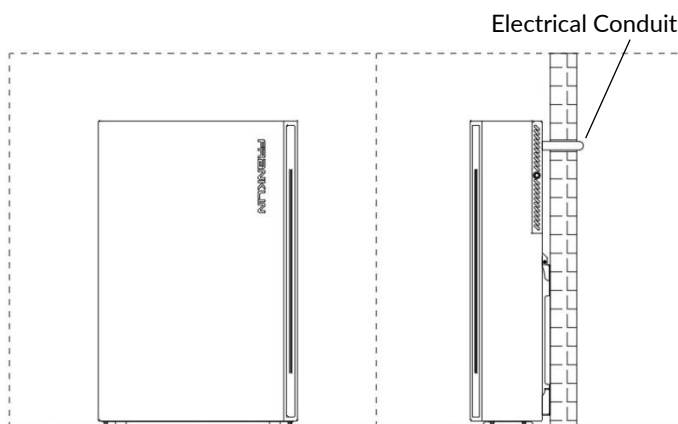

Sealing rings must be used.

A good seal must be guaranteed between the electrical conduits and the wiring compartment which can be achieved by using a conduit hub, sealing rings, or caulk.

2) aGate inputs and outputs

The positions of inputs and outputs on an aGate are as shown below. The following scenarios offer variations on the cable inlets and outlets of an aGate to accommodate variations in the existing residential wiring layout.

The knockout holes on the left and lower panel of aGate are 1.38 in. (35 mm) in diameter, while the plug hole on the upper panel is 2.49 in. (63 mm) in diameter. If the knockout holes do not match the electrical conduits in hub diameter, additional reducing fittings will be needed to achieve the required IP grade.



**WARNING:** It is recommended to install cables through the bottom of the aGate. If a top inlet cable is installed, waterproofing measures must be taken.

**Scenario 1:** aGate and electrical conduits share the same side of the wall.

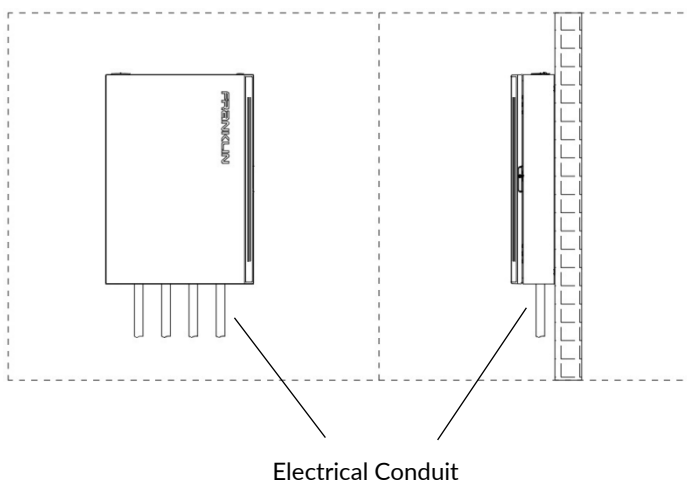

If the aGate is installed outdoors, the electrical conduit is connected to aGate through the cable inlet on the upper panel. Water-proof sealant or caulk should be used between the reducing fitting, hub, electrical conduit, and aGate to enhance the watertightness.

**Scenario 2:** Cables are run in electrical conduits and enter aGate from inside or through the wall.

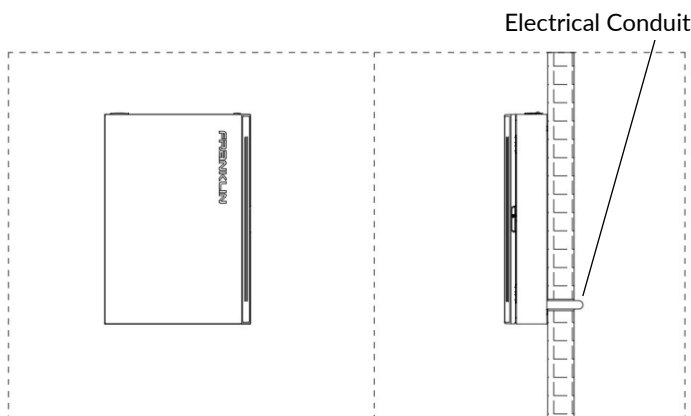

In this case, a conduit hub will be needed to ensure the IP grade of aGate.

### 3. Plan protection for aGate's input connections

The aGate serves as the entrance to the FHP system. Proper lightning protection measures are required. Over current protection measures are also required. A circuit breaker of 100 A to 200 A may be installed at the grid input connection and the generator input connection. Please refer to [Appendix 1](#) in this Guide for recommended circuit breakers.

### 4. Plan the types, sizes and routes of cable and electrical conduits

- 1) Please refer to [Wiring](#) for recommended cable types and wire diameters
- 2) As cables run through the electrical conduits
  - The current-carrying capacity of the cables needs to be reduced. Please refer to the applicable information in Appendix B of NFPA 70.
  - The relationship between wire diameters, cable numbers, and inner diameters of conduits should be taken into consideration. Please refer to Appendix C of NFPA 70 for the list of maximum numbers of cables of the same size in the electrical conduits and pipelines.
- 3) The type of electrical conduits depends on the installation type, indoor or outdoor.
  - IMC, EMT and other thin-wall metal conduits are recommended for indoor installations. These two types of conduits are cost effective, provide excellent anti-electromagnetic interference, and are easy to shape and to joint.
  - In outdoor installations, GRC and RMC thick-wall conduits are recommended because they can provide effective mechanical protection and good tightness at the conduit joints. Thick-wall conduits have a reduced flexibility disadvantage which makes bending and jointing very difficult.

### 5. Plan the Fire Control and Extinguishing System

The selection and installation of fire control and extinguishing systems on power storage systems must comply with the requirements of NFPA855 and local fire authorities.

### 6. FCC Requirements

See preface for the applicable FCC Requirements. The installer should inform customers of the contents in [Appendix 3](#).

## Tools Needed

- Personal Protection Equipment (PPE) (goggles, gloves, protective shoes, anti-dust respirator, etc.) to protect the personal safety.
- Drill
  - ✓ Use 5/32" Brad Point bits or 5/32" Auger bits to drill pilot holes in wooden walls.
  - ✓ Use 1/2", 3/4", 1", 1-1/2", 2" sized wood bits to create holes in wooden walls.
  - ✓ Use 1/2", 3/4", 1", 1-1/2", 2" sized hole saw bits to create holes in metal walls.
- Hammer drill
  - ✓ Use 1/2", 3/8" Masonry bits to create pilot holes on concrete or brick walls.
  - ✓ Use 1/2", 3/4", 1", 1-1/2", 2" Diamond core bits to create holes in concrete or brick walls.
- Electric screwdriver and cross screw bits to tighten the fastening screws.
- Torque wrench and bent-handle ratchet wrench.
  - ✓ Use 11/32", 5/16", 7/16", and 3/8" hex sockets, to tighten and check the torque of outer hex bolts.
  - ✓ Use 3/16" and 7/32" inner hex screwdriver bits to fasten cables at circuit breakers and pressure connectors and to check the torque.
  - ✓ Use 3/16", 1/4" straight screwdriver bits to fasten cables at circuit breakers and connectors and to check the torque.
  - ✓ Use PH2, PH3 cross screwdriver bits to fasten cables at circuit breakers and to check the torque.
  - ✓ Use 6" Phillips head extension.
- Flat head screwdriver (1/8" x 4", 1/4" x 4") to fasten signal terminals and take wooden boxes apart.
- Phillips head screwdriver (P H#2 x 4", PH #3 x 4") to tighten fasteners.
- Claw hammer to break knockout holes and to release locks on wooden box.
- Utility knife to cut open cartons.
- Needle nose, vise grip, wire stripper, wire cutter, utility wire shear, and other cable preparation tools.
- Wire crimper, network cable testers, wire tracker, and other network cable preparation tools.
- 14 mm open-end wrench or 9/16" open-end wrench to operate aPower leveling screws and to adjust the height of aPower.
- Induction electro probe to detect the cables in walls to avoid short circuits when drilling.
- Multimeter to measure voltage, current and other electric parameters.
- Loop resistance tester to measure the wiring resistance and to detect poor connection of cables.
- Task light to illuminate the area when power supply is off.

- Spirit level to check whether the equipment is leveled.
- Steel measuring tape to measure lengths.
- Markers to make drilling marks.
- Camera to record the installation process.
- Deep cut band saw to cut thin-wall steel conduit or PVC pipes.
- Lift equipment to transport and lift the aPower(s).
- Conduit bender to bend thin-wall steel conduits, with the head size depending on the types and sizes of conduits, with  $\Phi 1/2''$ ,  $3/4''$ ,  $1''$ ,  $1-1/2''$ ,  $2''$  benders.
- Knockout Tool Kit to drill holes for conduits on the distribution box case.
- Wooden block, size: 1.75 in.  $\times$  26.77 in.  $\times$  2.36 in. (44.4 mm  $\times$  680 mm  $\times$  60 mm).
- Adjustable wrench, size: 0-1.97 in. (0-50 mm).
- 6", 10", 18" Pipe Wrenches.

#### Torque Requirements

Screw Type	Cross head screwdriver	Tightening torque
M4	PH2	1.03 lbf·ft (1.4 Nm)
M5	PH2	2.21 lbf·ft (3.0 Nm)
M6	PH3	4.42 lbf·ft (6.0 Nm)

## Items Provided by Installers



1	Electrical conduit, conduit hub, pull box and fittings
2	Screws and M6 big spacers for wall installation
3	aPower combiner box (for parallel operation of multiple aPower units)
4	5/8 in. Type X plasterboard
5	Copper cables
6	Circuit breakers. For details, refer to <a href="#">Appendix 1</a> for circuit breaker models
7	Reducing washer conduit fittings
8	Network cable and registered jacks
9	Antioxidant conductive paste
10	Customer optional external CT
11	Sealant (for use on outdoor conduits)

## Unboxing

### Unbox the aGate

- 1) Inspect the package for damage.

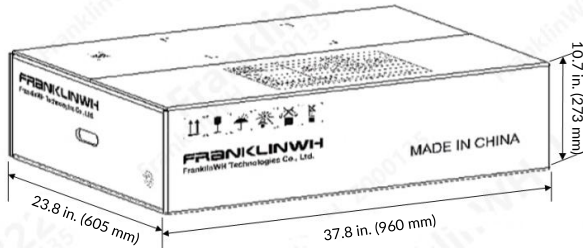

- 2) Adjust the utility knife until the blade is less than 0.3 in. (7.62 mm) long to protect the aGate from damage. Cut open the adhesive tape on the upper surface of the aGate carton.
- 3) Open the aGate carton, take out the template guide board and accessories, and then take the aGate out of the box.
- 4) Check if you have the following:

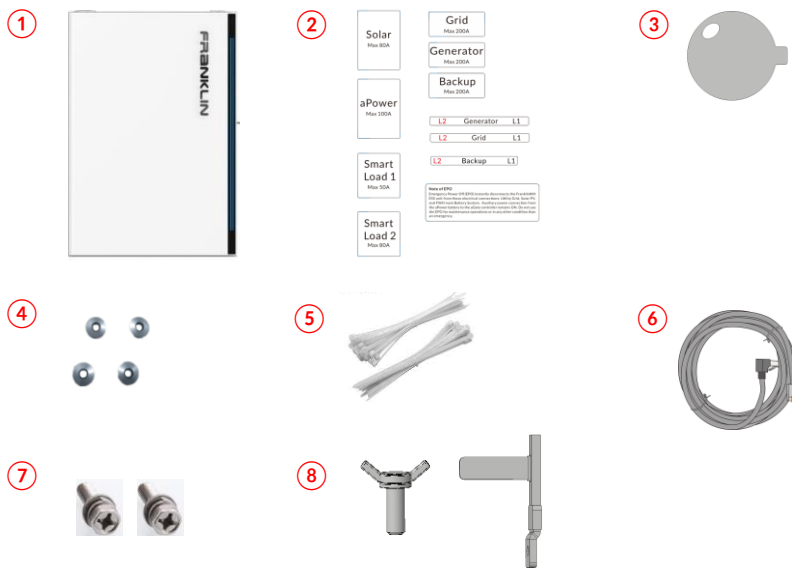

1	2	3	4
aGate	Switch tag	Grid relay reset handle toggle	(4) 1/4" water-tight washer
5	6	7	8
(20) Cable ties	5m communication cable	(2) Main switch mounting screw M4 × 10	aPower breaker fastener

- 5) Remove the packing foam from both sides of the aGate and remove the PE bag.

**Unbox the aPower**

- 1) Inspect the package for damage.

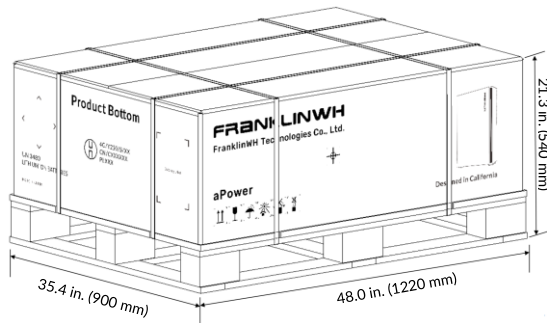

- 2) Cut the sealing tape and lift the cardboard cover.
- 3) Remove the protective carton and top foam.
- 4) Check if you have the following:

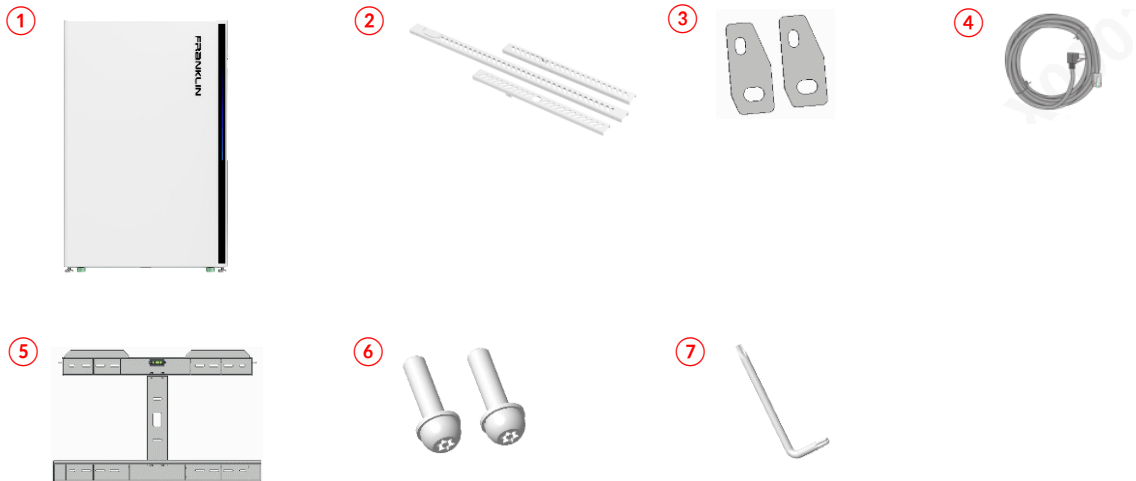

1	2	3	4	
aPower	Grille	(2) Retainer plate	2 m communication cable	
5	6	7	-	
Mounting bracket	(2) M5 x 20 screw	Wrench	-	

- 5) Stand up the aPower (logo faces up). Several installers should work together to protect the equipment from falling.
- 6) Using a lift, move the aPower to the installation site.



**NOTE:** Please wrap the aPower in a protective blanket and keep the aPower well fastened during the transportation and handling process to avoid scratches or damage.

## Installation



**DANGER:** Special care must be taken to protect personal safety. Reinforced toe shoes must be used to protect the installers in case equipment tilts and falls.



### aGate Installation



**WARNING:** Add lightning protection measures per NFPA 780, UL96A, and LPI-175.



**NOTE:** The drill template guide board will be used for drilling mounting holes. Keep it in good condition prior to use.

The film wrapped around the aGate will be used to protect the internal components of the aGate when drilling mounting holes. Do not tear the film until the drilling is complete.

During the installation process, keep the aGate well protected from hard objects that may scratch the aGate surface and body.

#### Remove the door and inner panel from the aGate

##### 1) Remove the door

- a) Grasp the small notch on the right side of the aGate. Lift it slowly until the door of aGate is completely open.

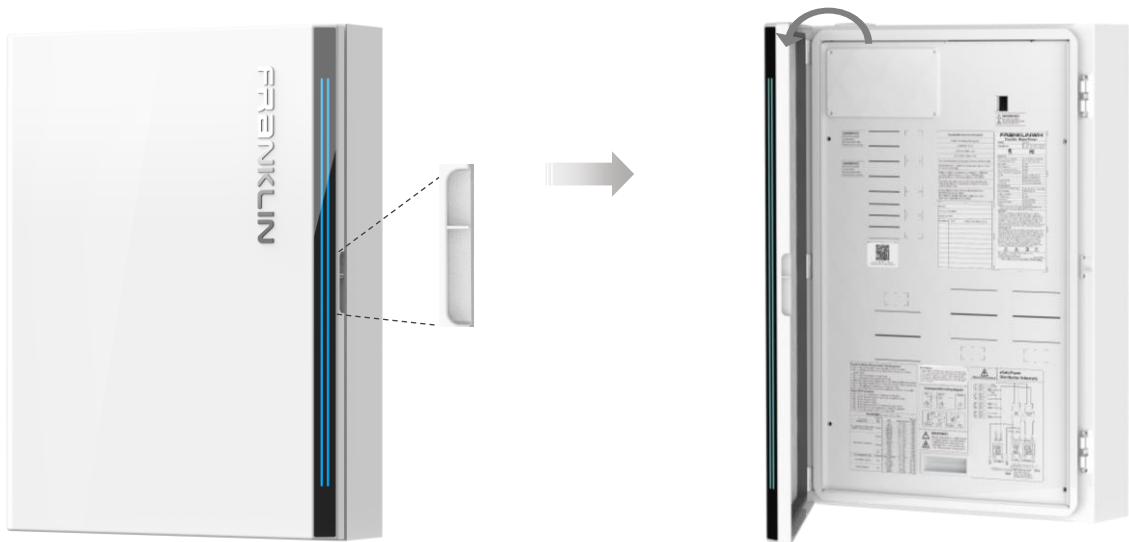

**WARNING:** The door may only be opened to a maximum of 100°, beyond which the door may crack.

- b) Gently lift the door panel upward, remove the aGate door after the hinges are separated, and properly store it.

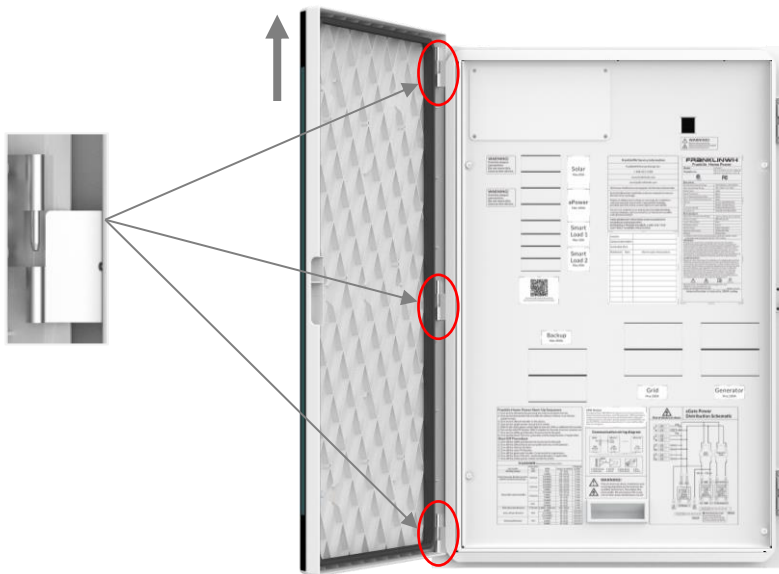

## 2) Remove the inner panel

Using a Phillips head screwdriver or an electric screwdriver with a Phillips head screw bit, turn the 4 combination screws fastening the inner panel counterclockwise until the screws are loosen. Remove the screws, and the aGate inner panel. Properly store the inner panel and screws for later use.

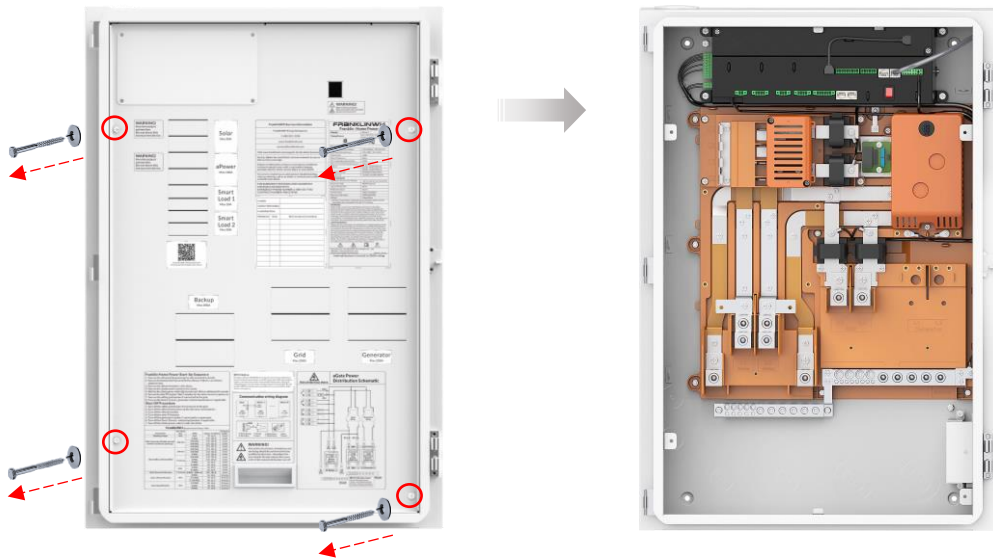

**WARNING:** Improper operation may result in the bolt being seized.

## Prepare aGate cable inlets

Based on the preplanned installation position and electrical conduit arrangement, remove the appropriate plug or knockouts in the aGate.

### 1) Remove the plug

The plugged hole on the top of the aGate enclosure is 2-15/32" (62.71 mm) in diameter. If the top cable entry is used, turn the plug nut counterclockwise by hand, until the nut is removed, then remove the plug.

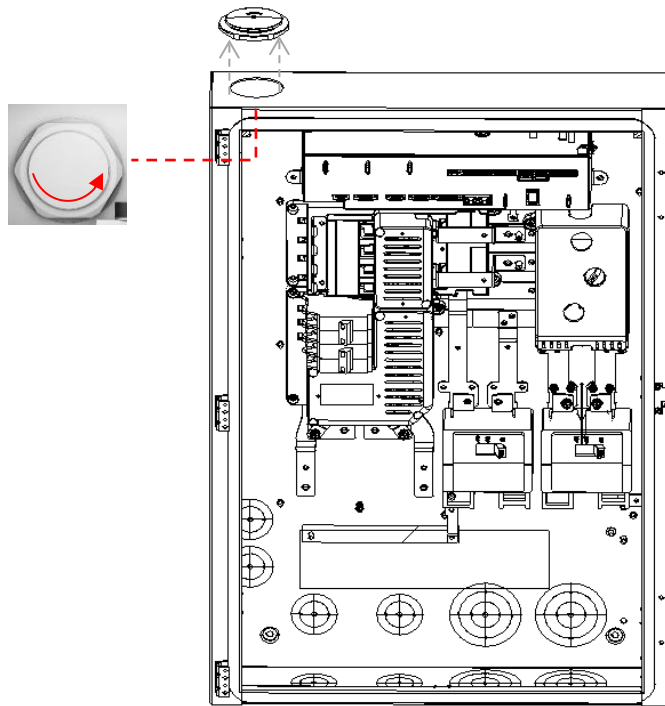

**WARNING:** It is recommended to install cables through the bottom of the aGate. If a top inlet cable is installed, waterproofing measures must be taken.

### 2) Remove the knockouts

All cable knockouts in the aGate enclosure are 1-23/64" (34.53 mm) in diameter with the two on the rear right, and the two on the bottom right can be expanded to 2-15/32" (62.71 mm).

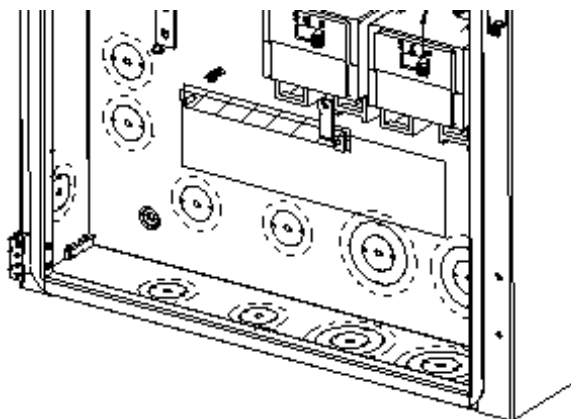

Drill out the necessary cable access holes on the aGate.

## Enlarging or Drilling New Holes (if necessary)

If the conduit diameter is larger than the aGate knockout hole, or if any new hole needs to be drilled, appropriate tools should be used to expand the hole or to drill new holes.



**WARNING:** To avoid damage to equipment, shield all aGate interior electrical boards and components before you drill or punch holes, to avoid debris falling into the aGate.

**Tip:** The aGate is shipped in a protective film. When enlarging or drilling new holes on the aGate, unwrap the outer film and use it to protect the components inside the aGate. Keep the film in place while drilling and punching holes. Remove all dust and debris before unwrapping the aGate for mounting.

## Install optional module(s)

FranklinWH provides optional Smart Circuits and Generator Modules. For Smart Circuits Module and Generator Module installations, refer to [FranklinWH Smart Circuits Module Installation Guide](#) and [FranklinWh Generator Module Installation Guide](#).

## Install breakers as needed

Install breakers for solar, aPower, Smart Circuits (if Smart Circuits Module installed), the backup panel, grid, and generator (if Generator Module installed), according to local laws, regulations, standards, and National Electric Codes (NEC), ANSI/NFPA 70 or Canadian Standards Association CSA C22.1. These breakers are not included and must be ordered separately. Refer to [Appendix 1](#) for compatible breakers.

Breaker installation positions are noted in the image below:

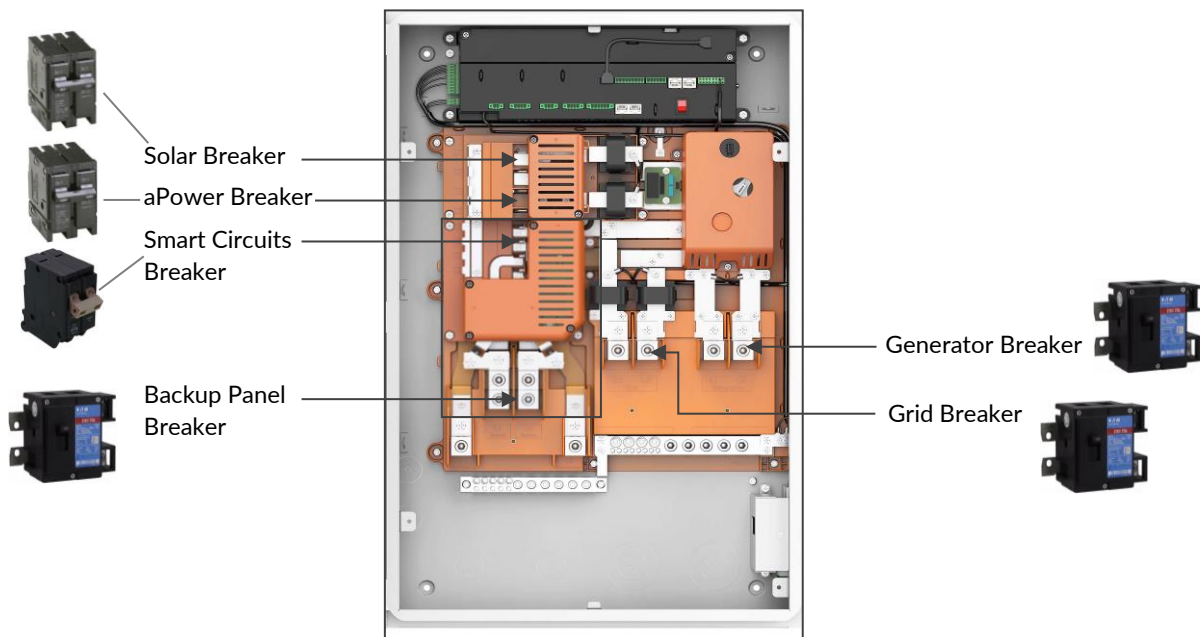

- 1) Before installation, make sure that the aGate is de-energized and the upstream and downstream switches are disconnected and padlocked during installation.
- 2) Install a solar breaker, an aPower breaker, and smart circuits breakers at the location indicated on the image above.
- 3) Fasten the aPower breaker according to the following steps as per NEC requirements.

- a) Insert the circuit breaker holder card firmly into the middle space of the aPower breaker in the direction shown in the image below.

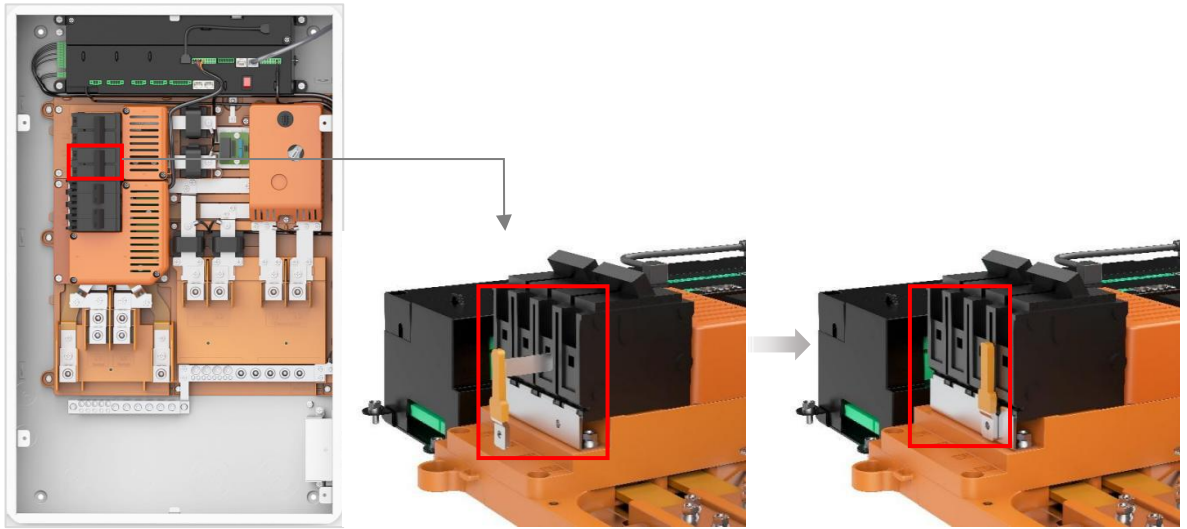

- b) Insert the fixing plate, turn the screw by hand to seat the circuit breaker.

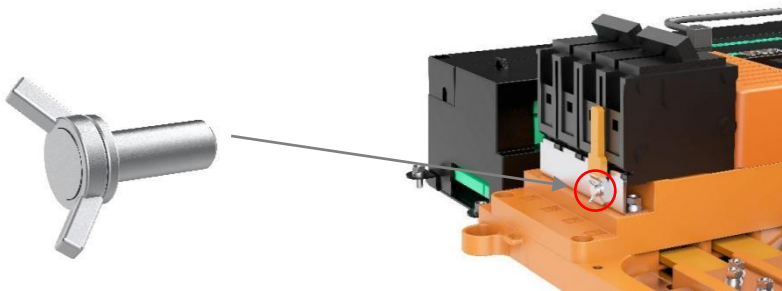

- 4) Before installing a backup panel breaker, a grid breaker or a generator breaker, remove the connected lugs. When breakers are used, the lugs are replaced with breakers during installation. When breakers are not installed, the conductors can be directly connected to these lugs. Follow the instructions below to remove the lugs and install the breakers:
- Using a Phillips head screwdriver, remove the two M6 x 16 combination bolts holding the lugs and save it for later use. Then remove the lugs.
  - Use the two M6 x 16 combination bolts to fix the breaker. Then use the M4 x 10 screw to secure the breaker. Using a Phillips head torque screwdriver, tighten the M4 screw to 1.03 lbf·ft (1.4 Nm).
  - Stick the provided **L2 Backup L1**, **L2 Grid L1**, and **L2 Generator L1** labels below backup panel breaker, the grid breaker, and generator breaker respectively.

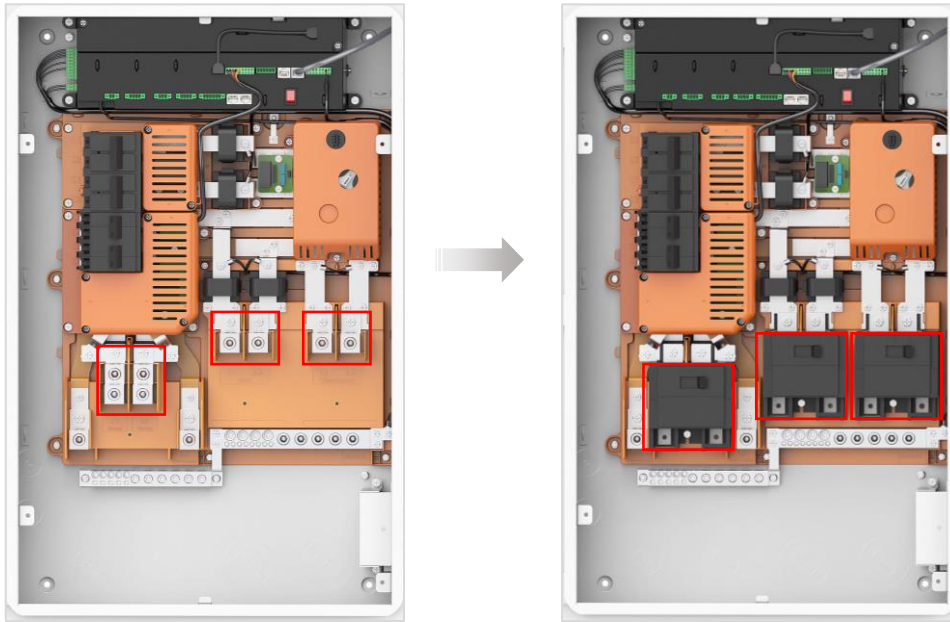

**NOTE:** The aGate's utility grid circuit breaker is only required where the aGate is used as service entrance equipment or there are no other circuit breakers protecting the conductors feeding the aGate's utility grid connection.

The generator breaker may be installed outside the aGate depending on the site condition.

### Mount the aGate on a wall

Follow the procedures below to install the aGate on a wall.

- 1) Place the aGate guide board template at the planned installation position. Use a level to adjust the guide board to level, and then make marks at the four holes on the guide board.
- 2) Using an appropriate drill bit, drill holes in the wall. Then mount the aGate enclosure vertically on the wall. The provided water-tight washers must be used when mounting the aGate.



**DANGER:** Avoid drilling holes in water pipes and cables in the wall.



**WARNING:** Cover any nearby aPower top heat dissipation hole during drilling to protect from gravel dust.

See drilling details and the fasteners in the table below for more details on the hole depth and type of fasteners to use corresponding to different type of wall.

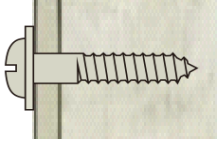
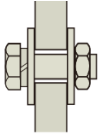
<p><b>Concrete or brick structures</b></p>	<p><b>Hole depth:</b> Minimum 1-1/2" (38 mm)  <b>Fastener:</b> 1/4" (6.35 mm) water-tight washer, spring washer, and nuts</p>	
<p><b>Wooden beams</b></p>	<p><b>Hole depth:</b> Minimum 2.5" (64 mm)  <b>Fastener:</b> 1/4" (6.35 mm) water-tight washer, wood screw with a large flat washer,</p>	
<p><b>Steel beams</b></p>	<p><b>Hole depth:</b> Through the steel beam  <b>Fastener:</b> 1/4" (6.35 mm) water-tight washer, 1/4" (6.35 mm) stainless steel hex screws with spring washer and large flat washer and hex nuts</p>	

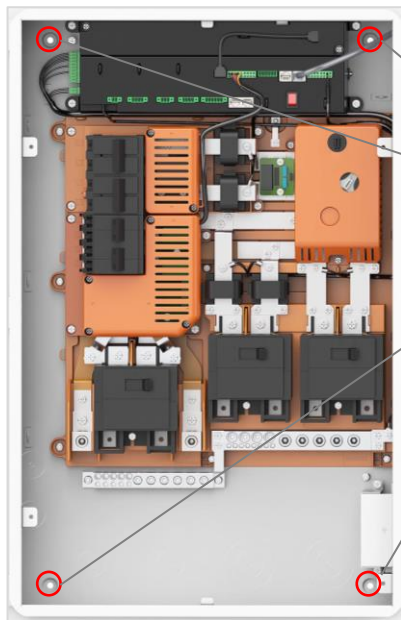

For demonstration only.  
 Use fasteners specified in the table above.

## aPower Installation

### Mount the bracket

- 1) Before mounting, examine the smoothness of wall.

If the wall is not smooth and straight to the floor, Type X plasterboards will be needed to fill the gaps to ensure all parts of the mounting bracket are well supported by the wall.

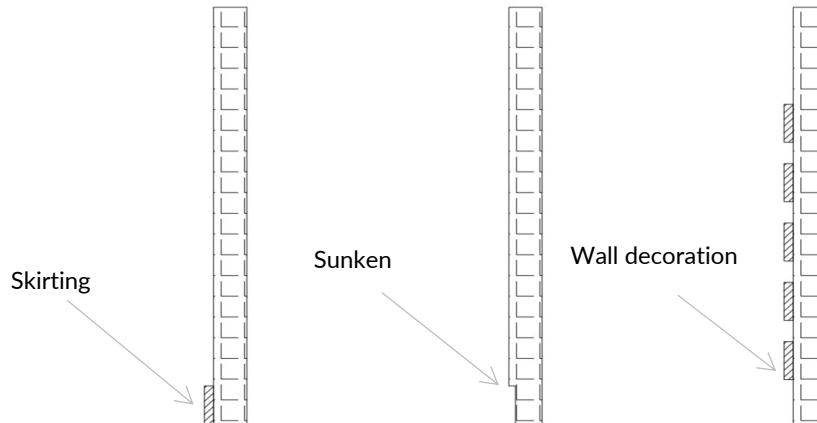

### Special Wall/Baseboard Installation

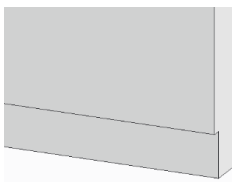
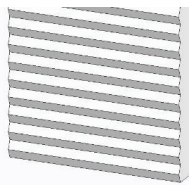
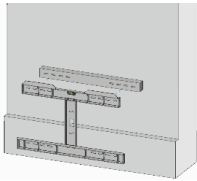
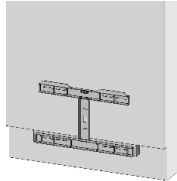
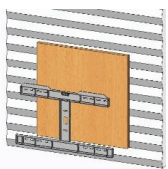
<b>Case 1: Protruding Baseboard</b> Height > 6 in. or the thickness of the bulge > 1 in. (Floor mount)	<b>Case 2: Concave Baseboard</b> Height > 6 in. (Floor mount)	<b>Case 3: Uneven Wall</b>
		
<b>Solution</b> Use wooden or steel spacers on the upper part of the bracket (to keep it flush with the baseboard).	<b>Solution</b> Use wooden or steel spacers on the indented baseboard (to make it flush with the wall).	<b>Solution</b> Use plywood or gypsum board to level the wall. The recommended thickness is 0.5 in.
		



**NOTE:** The wooden or steel materials are prepared by the installer.

2) Determine bracket mounting points

The mounting bracket should be fastened to the wall at a minimum of 4 points, one on each arm. When the bracket is attached in the outdoor, windy area, at least 12 1/4" screws (3 at each corner) should be used to mount the bracket.

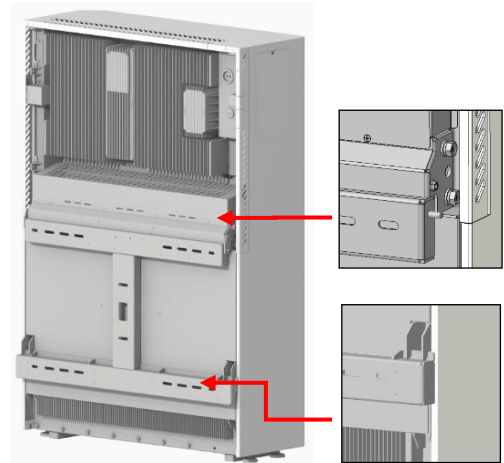
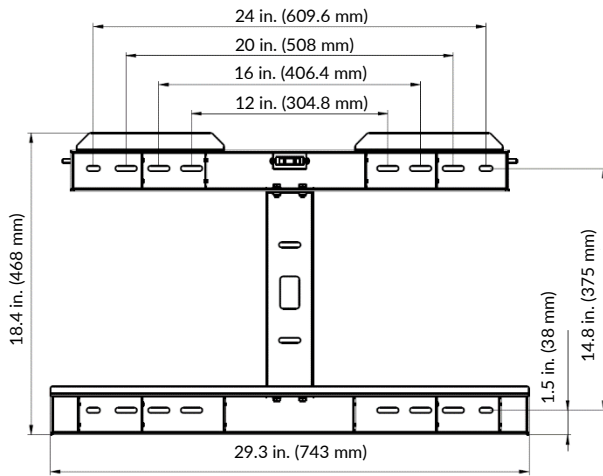

Determine bracket mounting points following the methods described below.

a) Method 1: Use the bracket to mark the mounting points.

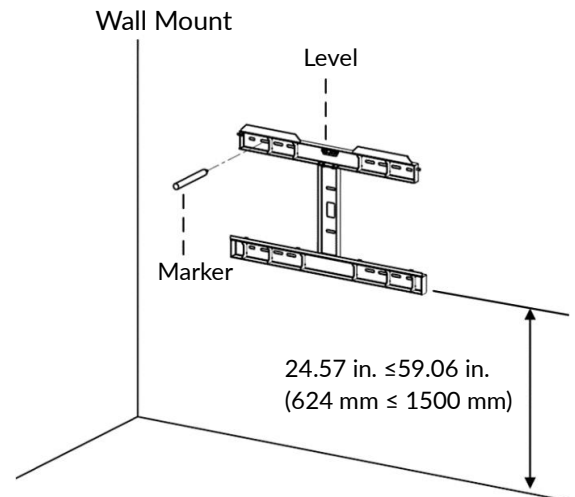
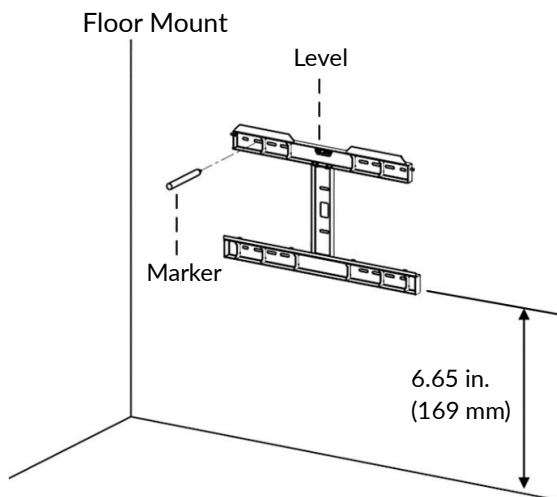

b) Method 2: Use the cardboard positioning template to mark the mounting points.

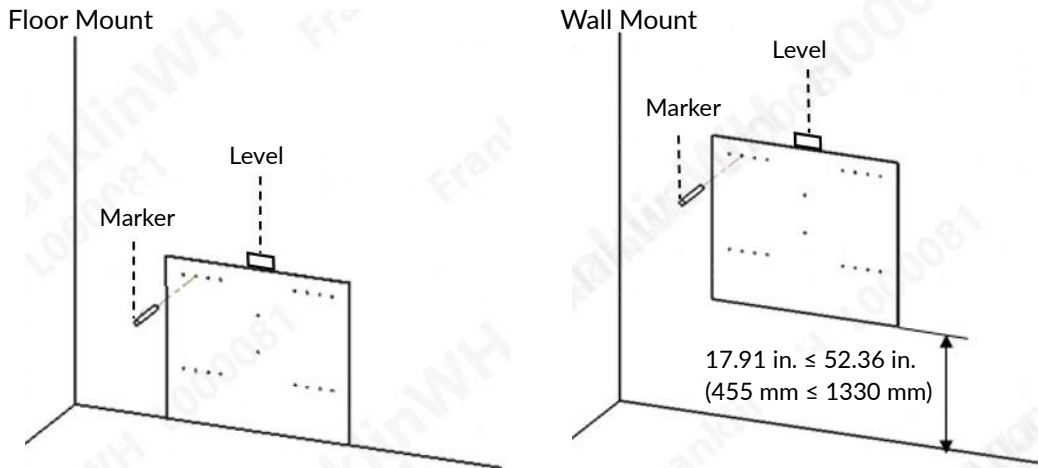

3) Mount the bracket

<p><b>Wooden beams</b></p> <p>At least 4 1/4" stainless steel wood screws with large flat washers (1 at each corner), at least 2.5" (64 mm) of each screw inserted into the wooden beam.</p>	
<p><b>Steel beams</b></p> <p>Use at least 4 1/4" stainless steel hex screws (1 at each corner) with spring washers, large flat washers and nuts to secure the bracket to the steel beam.</p>	
<p><b>Concrete or brick walls</b></p> <p>Use at least 4 1/4" stainless steel expansion screws (1 at each corner) with spring washers and large flat washers and at least 1.5" (38 mm) length embedded in the wall. Place screws at least 1.5" (38 mm) away from brick edge</p>	

**Drill conduit entry holes on the wall (if needed)**

Drill conduit entry holes on the wall if needed. If there is any metal or wooden supporting structure in the drilling area, necessary adjustments are required to avoid it.



**DANGER:** Avoid drilling holes in water pipes and cables in the wall. PPE must be used in the operation.



**WARNING:** Cover the aPower top heat dissipation hole to protect from gravel dust during drilling.

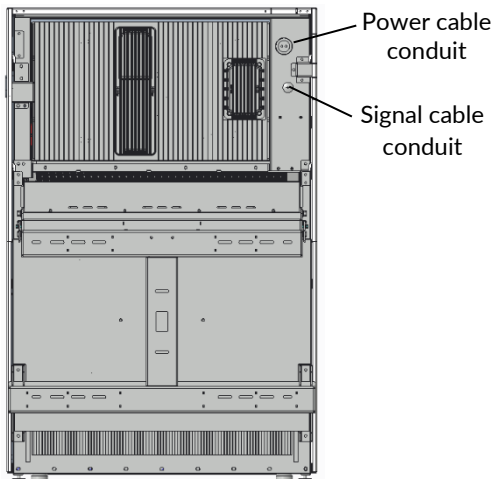

Rear View

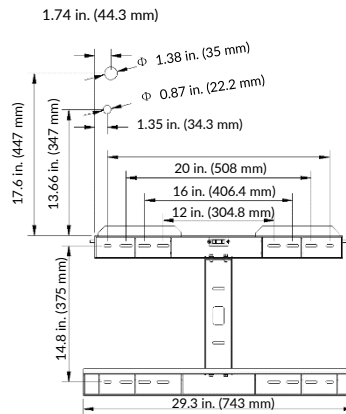

Front View: Positions of mounting bracket and conduits on the equipment

	<p><b>Wooden wall</b></p> <p>Electric drill and 1", 1-1/2" wood bits are recommended to create holes for running cable through wooden walls.</p> <p>It is important that the drill bit be kept perpendicular to the wall when drilling.</p>
	<p><b>Concrete or brick wall</b></p> <p>Hammer drill and 1", 1-1/2" diamond tipped core bits are recommended to create holes for running cables through concrete or brick walls. Wet the wall and HEPA vacuum the dust, to protect the drill bits from overheating.</p> <p>It is important that the drill bit should be kept perpendicular to the wall when drilling.</p>
	<p><b>Metal wall or metallic studs</b></p> <p>Electric drill and 1", 1-1/2" hole saw are recommended to create holes for running cables through metal plate and metallic studs.</p> <p>It is important that the drill bit should be kept perpendicular to the installation surface when drilling.</p>

## Mount the aPower in the bracket



**DANGER:** Special care must be taken to protect personal safety. Reinforced toe shoes must be used to protect the installers from tilting and falling equipment.



**WARNING:** Use proper protective measures on the lift, such as foam or protective cloth, and take effective protection measures to avoid scratching or damaging the aPower during the installation process.



**NOTE:** For easy installation, before wall-mounting the aPower, refer to [Electrical Conduits](#) to remove the aPower wiring compartment cover, 3 external charging cables and cable conduit hole-plug 1/2, then pre-install the pull box (Protect the wiring compartment well to prevent damage to the interface board).

- 1) A lift is needed to raise the aPower.

Raise the aPower so that top mounting cleats on the back of aPower is higher than the top of the mounting bracket.

Adjust the lift until the mounting bracket is completely aligned to the clips on the back of aPower and within the locking position of the joint, and the top and bottom mounting cleats are firmly locked by the mounting bracket. During this process, the installer needs to push on the front of the aPower to ensure that the back side locks securely into the mounting bracket.

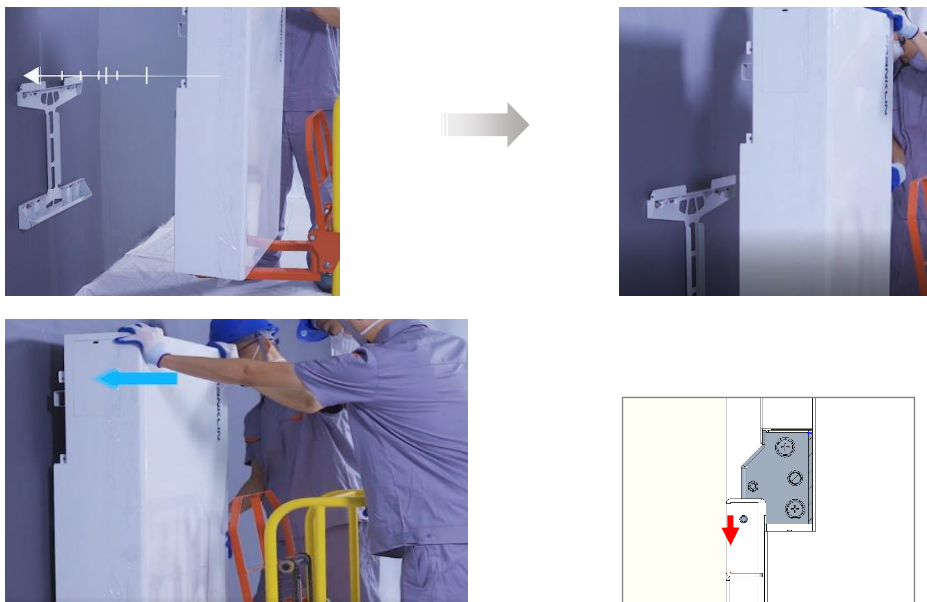

- 2) After the aPower is firmly set on the mounting bracket, attach and fasten the two retainer plates to both sides of the upper bracket using M5\*20 screws, tighten to a torque of 3 Nm.

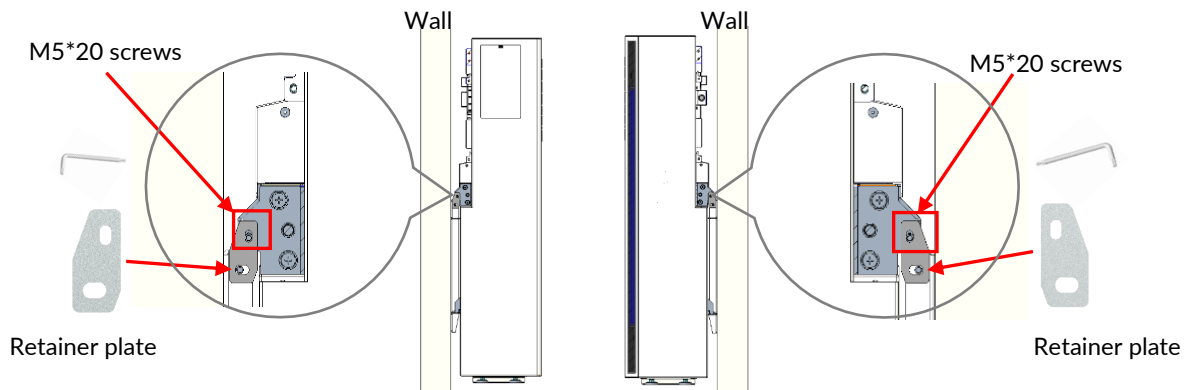

### Level the floor mounted aPower

If the aPower is to be installed on an uneven floor, the leveling screws on the bottom of aPower cabinet can be adjusted until the screw directly contacts the floor.

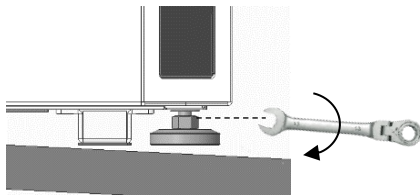
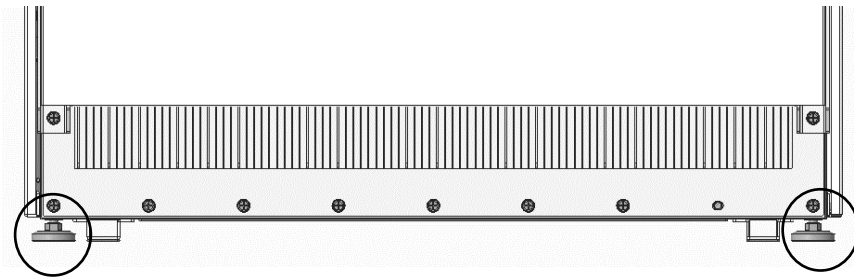

Using a No. 13 open-end wrench, turn the nut clockwise to loosen it.

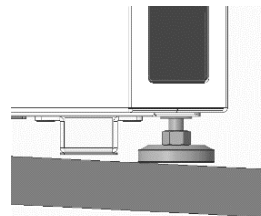

Turn the bolt head clockwise until the screw head hits the ground.

### Install a Combiner Box (if needed)

The installation of multiple aPower units requires a combiner box installed. Each aPower should be connected to a 2-pole breaker. Select a suitable external combiner box and determine the quantity of breakers in accordance with the number of aPower units in parallel operation. For details, refer to [Table 7](#) in [Appendix 1](#).



**NOTE:** Refer to the manufacturer's instructions before installation.

## System Wiring

### Install Electrical Conduit on the aPower Wiring Compartment

- 1) Remove the wiring compartment cover on the aPower

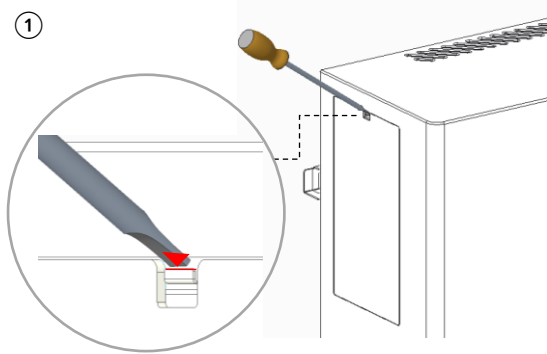

Use a 1/4" x 4" flat head screwdriver and insert it into the snap joints, press and pull the cover out.

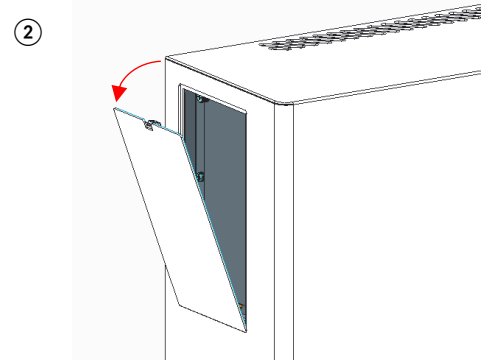

Lift the cover upward.

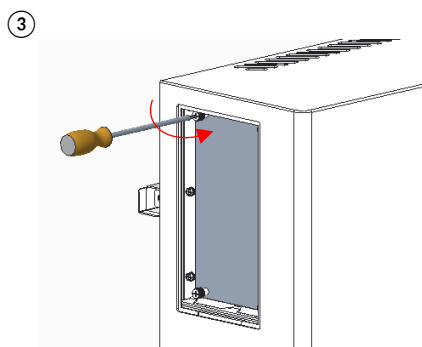

Remove screws fastening the internal panel. Turn them counterclockwise using a Phillips head screwdriver.

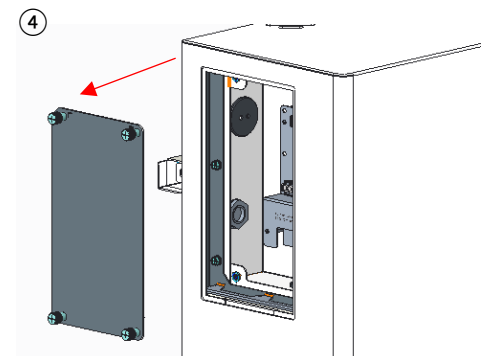

Remove the cover.

- 2) Unplug the 3 external charging cables.

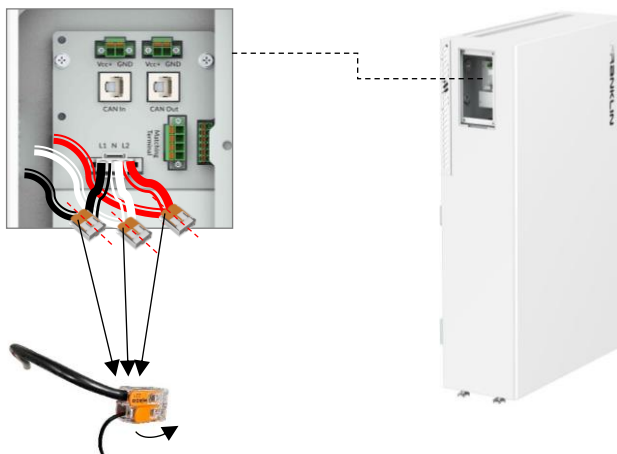

Open the clip and pull out the 3 cables.

- 3) Remove the protective ring and cable conduit hole-plug as needed.

To remove the cable conduit hole-plug, turn the plug counterclockwise using a bent-handle ratchet wrench with a Phillips head until it's loosened, while keeping the interior fastening nut in position. Then rotate it by hand until the plug is removed.

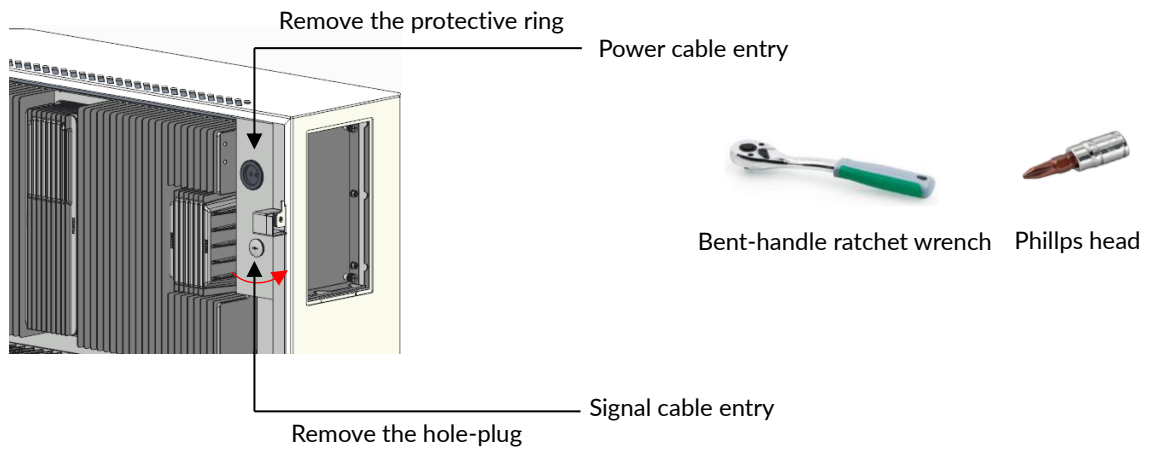

- 4) Conduit Connection and Installation

Install conduit as needed and attach the conduit fitting to the cable entry of aPower wiring compartment.



**WARNING:** The conduits and related materials must comply with UL746B requirements as well as all local laws and regulations.

Metallic conduits and fittings are recommended to minimize electromagnetic interference.

Install a pull box behind aPower cable hole as needed.

- a) Select an appropriate pull box according to the cable distribution direction (The figure below is for reference).

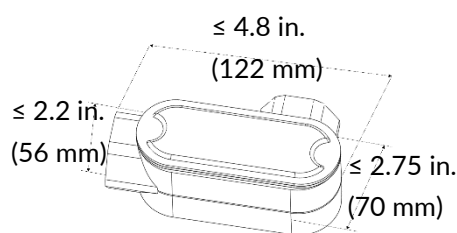

- b) Use a Phillips head screwdriver to take apart the junction box. Then install the pull box on the selected cable entry.

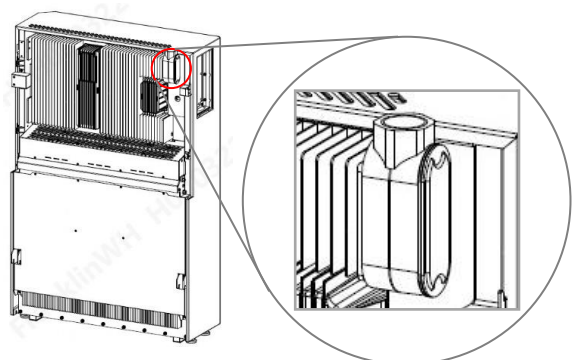
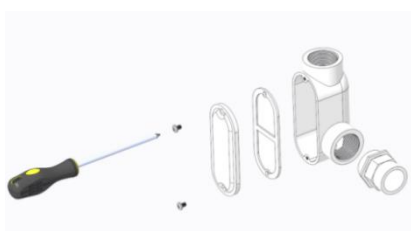

## Communications Wiring

Before wiring, check and ensure that the Com Kit (4G and Wifi) cable is connected between the Com Kit port on the EMS module and the Wireless module.

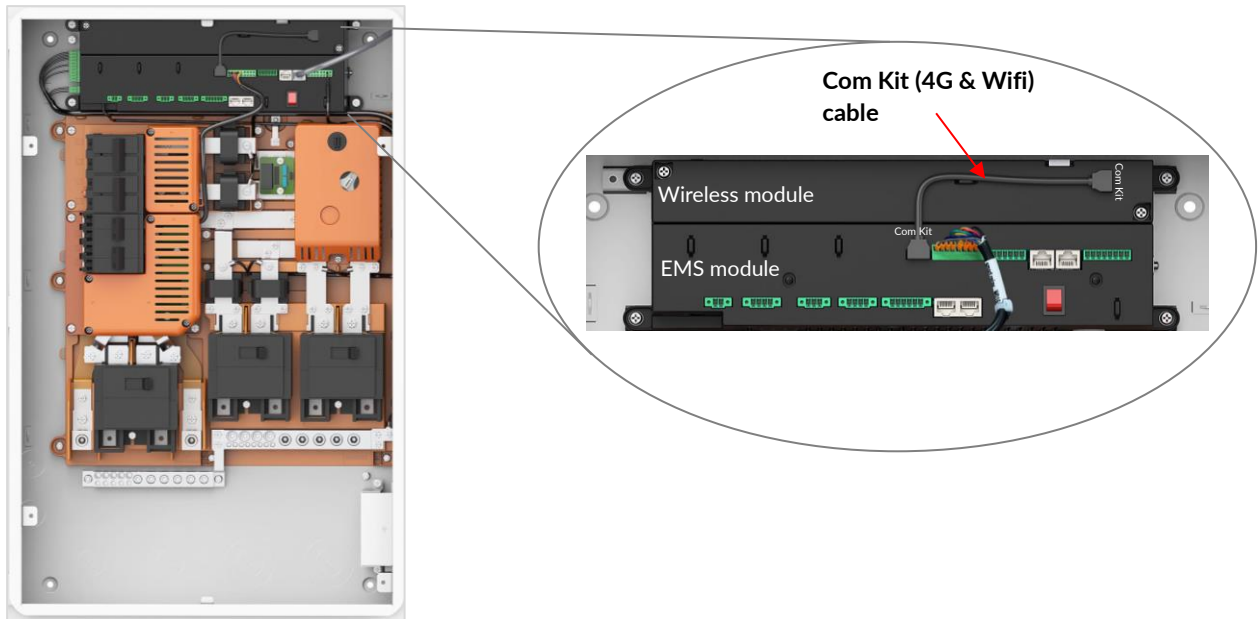

**WARNING:** Only use the cable supplied with the equipment. The aGate cannot be activated if this step is not completed.

### 1) Establish communications between the FranklinWH App and the aGate

Connect the mobile device to the aGate hotspot network to establish a local communications connection between the FranklinWH App and the aGate using the following account and password:

**Account:** AP\_last 9 digits of serial number

**Password:** last 12 digits of serial number



**NOTE:** The account and password can be modified through the FranklinWH App.

### 2) Connect the aGate to the home internet network for remote access.

- a) Method 1 (Recommended): Connect the aGate to the home internet using a communications cable (Not provided).

To ensure the reliability of remote communications, it is recommended to connect the home network cable with internet connection to the **Eth2** port of EMS module.

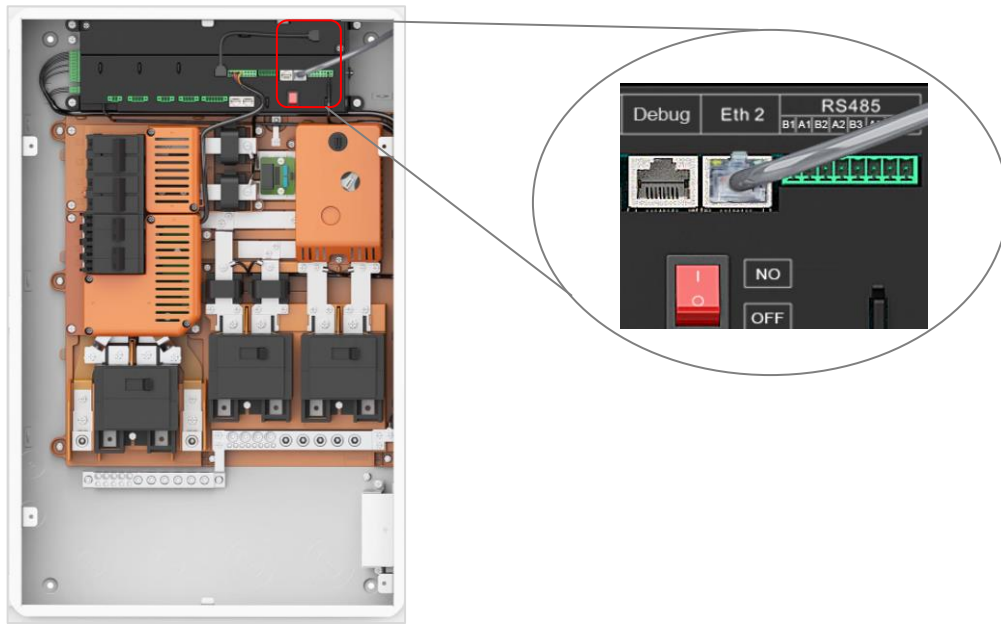

**WARNING:** The cable from the home network may only be connected to the **Eth2** port, as Debug (**Eth1**) port serves for debugging.

The communications cable needs to be made on site using a crimping tool, a ready-made network cable should not be used. Otherwise, the bending of cable inside the aGate may prevent the internal cover from closing. Test with a network cable tester to ensure that the cable contact is error-free.

#### Communications cable preparation:

- i. Remove the insulation jacket from the cable.
- ii. Fan the wires in the order of 568B (See wiring scheme diagram).
- iii. Insert the wires into the connector.
- iv. Crimp the connector using a crimping tool and then the cable is ready.
- v. Test with a network cable tester to ensure that the communications cable contact is error-free. Before testing the cable, ensure that both ends of the cable are disconnected from the FHP.

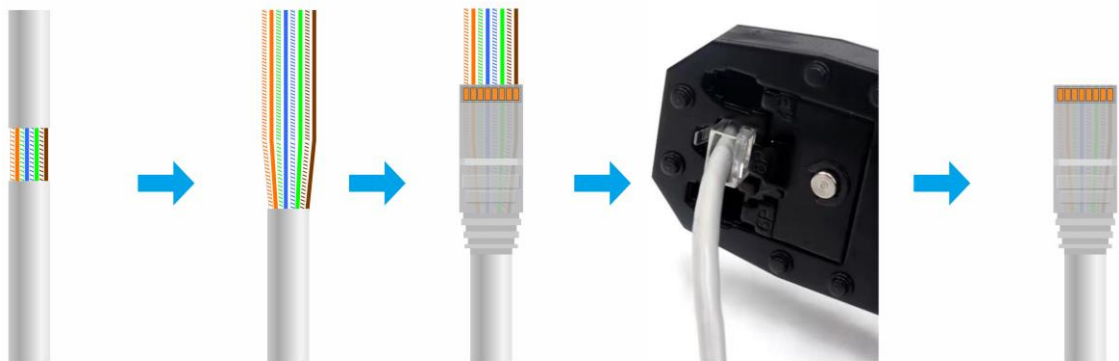

#### Wiring scheme:

The communications cable wiring must conform to the 568B standard sequence.

- Pin 1: white/orange,
- Pin 2: solid orange,
- Pin 3: white/green,
- Pin 4: solid blue,
- Pin 5: white/blue,
- Pin 6: solid green,
- Pin 7: white/brown,
- Pin 8: solid brown.

RJ-45 Pin	1	2	3	4	5	6	7	8
Pair	2	2	3	1	1	3	4	4

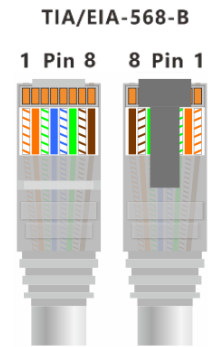
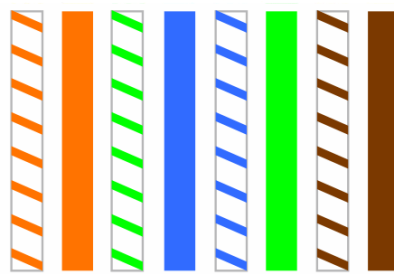

b) Method 2: Connect via Wifi

The Wifi connection between the aGate and home wireless network should be done during commissioning. Please refer to the **Franklin Home Power Commissioning Guide**.

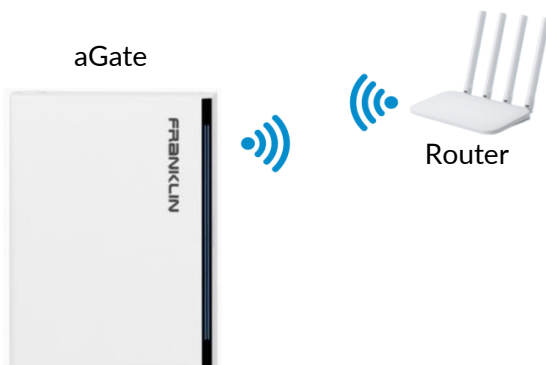

**\*NOTE:** The aGate supports only 2.4Ghz Wifi connection to the family router.

c) Method 3: Connect via telecommunication 4G network (only as backup)

Please make sure that there is a good 4G LTE signal in the local area and that a SIM card has been inserted into the slot on the wireless module.

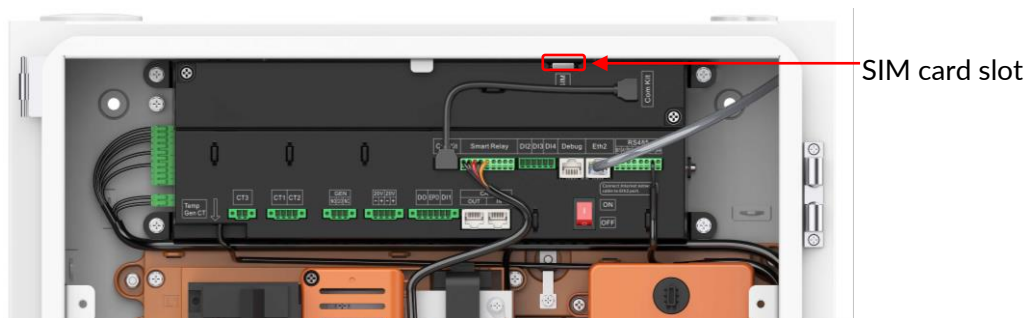

3) Establish communications between the aGate and the aPower



**NOTE:** It is recommended to install the communications cable in the conduit to avoid accidental damage and equipment failure. If the network cable and the power cable share the same conduit, use a shielded network cable (RJ45 cable end with metal).

Before connecting the communications cable, test it with a network cable tester to ensure that the cable contact is error-free.

a) Communications connection between the aGate and a single aPower

If the distance between the aGate and the aPower is within 98 ft (30 m), use a minimum CAT5 cable to connect the aGate **CAN OUT** port to the aPower **CAN In** port in the wiring compartment.

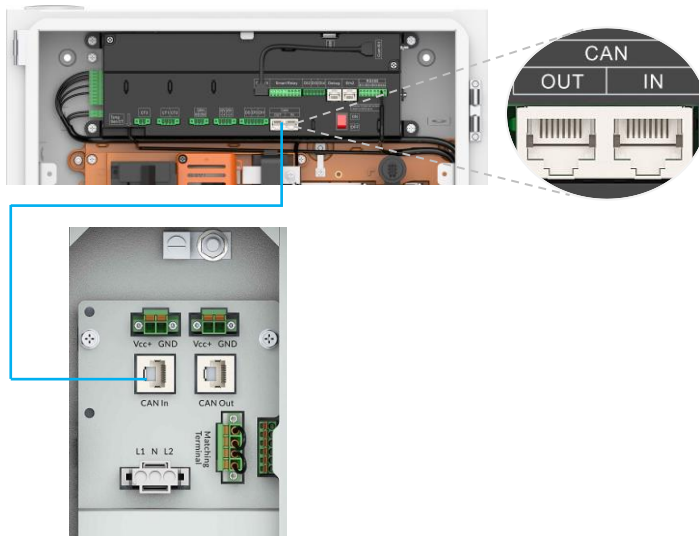

If the distance between the aGate and the aPower is more than 98 ft (30 m), a 16~18 AWG 20 V power supply feed will be needed in addition to the communication cable. Connect the aGate **20V +/-** ports to the aPower **Vcc+** ports, as shown in the image below.

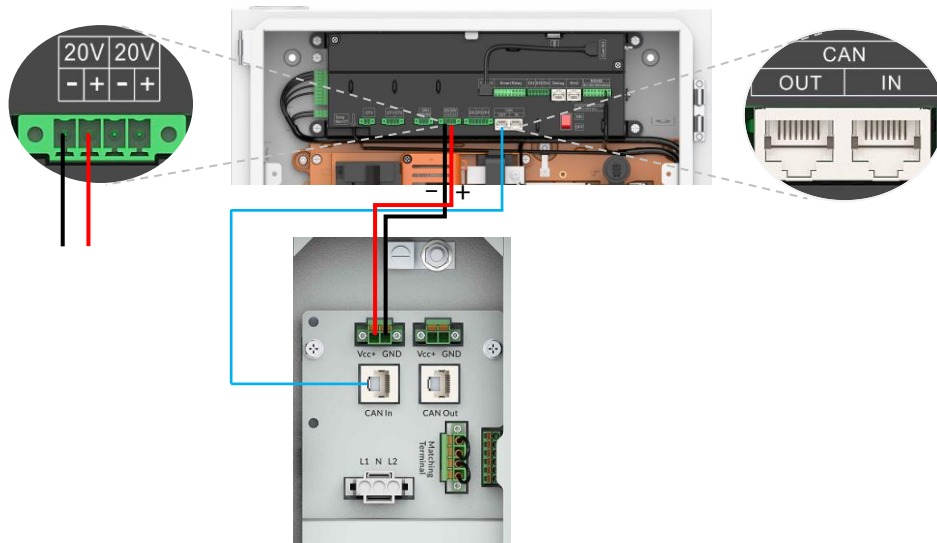

b) Communications connection between the aGate and multiple aPowers

If the distance between the aGate and the first aPower is within 98 ft (30 m), use a minimum CAT5 network cable to connect the aGate CAN-OUT port to the CAN In port of the first aPower, and connect the CAN OUT port of the first aPower to the CAN In port of the second aPower, etc.

Remove the matching terminals from all aPower units except for the one of the last aPower.

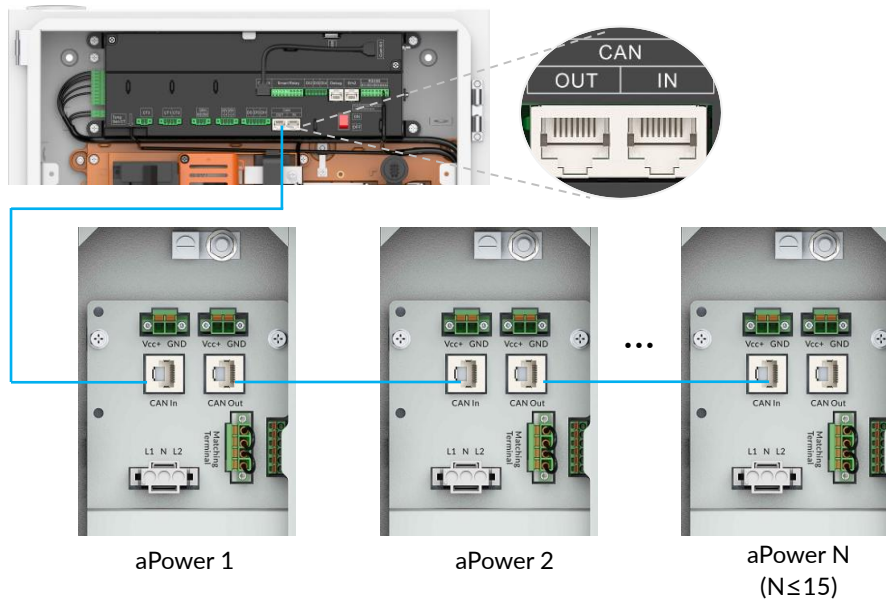

If the distance between the aGate and the first aPower is more than 98 ft (30 m), a 16~18 AWG 20 V power supply feed will be needed in addition to the communication cable. Connect the aGate 20V +/- ports to the Vcc+ ports of the first aPower, as shown in the image below. Remove the matching terminals from all aPower units except for the one of the last aPower.

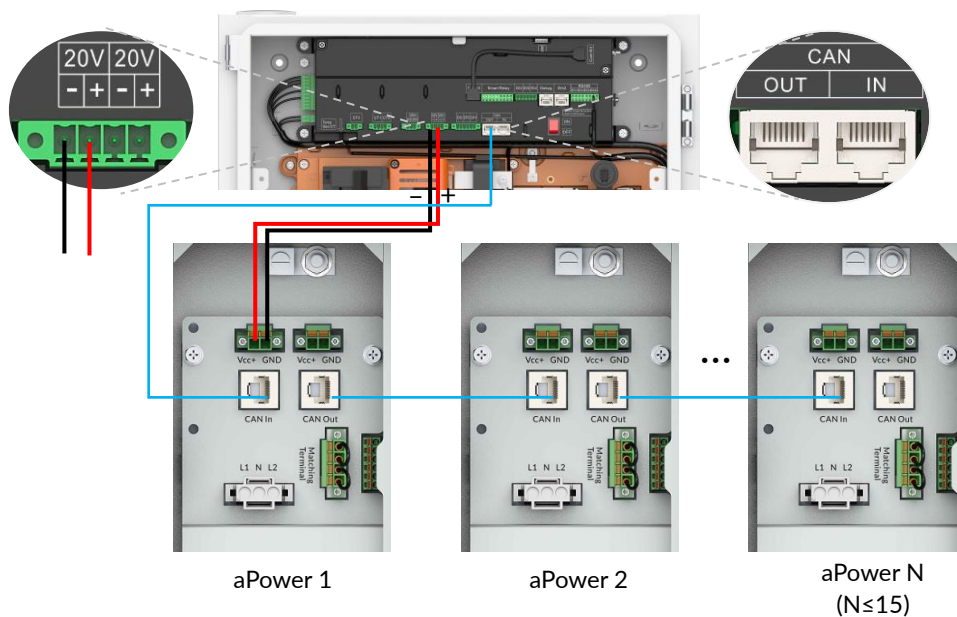

When the system needs to be connected to the 20 V power supply, the terminal does not need to be removed. Just press the orange switch on the port in the first aPower wiring compartment, insert the prepared wire, and then release the switch to complete the wiring.

**The 20 V power cable preparation:**

- i. Run the 16–18 AWG 20 V power cable through the electrical conduit. Refer to the local regulations for the cable colors.
- ii. Remove the insulation jacket on both ends by 0.43 in. (10.9 mm).
- iii. Connect the wires to the corresponding terminals.

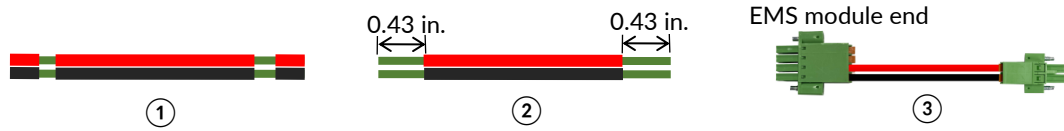

Electrical Wiring



**NOTE:** The wiring of breakers should follow the specific breaker instructions. The power sources must be connected to the aGate at the corresponding ports.

The cable conductor size and current capacity rating are listed in the NFPA 70, Article 310.

Conductors, relied upon for the protective grounding and bonding system, will be sized to handle the intended fault currents and, if insulated, the insulation will be green or green with yellow stripes.





Grounding conductors are sized following NFPA 70 Article 250.122 of or C22.1 Rule 10-810.

A field wiring terminal or lead shall be rated for the connection of a conductor or conductors having a minimum carrying capacity rating of 125 % of the rating of the unit.

The distance between the end of the connection point of a field-installed wire and the wall of the enclosure to ward which the wire is to be directed, shall be following NFPA 70 Table 312.6 (A) or (B).

Please be sure to apply antioxidants to the aluminum cable stripped surfaces.

Cables selection will consider metal compatibility. Please refer to Figure F.1 of Appendix F in the UL9540 standard.

	<p><b>DANGER:</b> The power cables should be wired in a sequence of the load side, the backup power supply side, and the non-backup power supply side. If the other end of a cable cannot be wired at the same time, a warning sign <b>Out of Operation, Do NOT Turn On</b> should be hung.</p>
	<p><b>DANGER:</b> aGate and aPower units do not have any indoor-level lightning protection feature, so customers should configure lightning protection equipment where the grid power runs into the house.</p>
	<p><b>DANGER:</b> Please follow the <b>Local Precedence</b> rule. Remote control does not mean that the local circuits are safe. Please decide whether your circuit is safe based only on a circuit test.</p>
	<p><b>DANGER:</b> Electrical connections require that the wires are connected in correct order, where L1 and L2 cannot be misconnected. Incorrect wiring may cause equipment damage or even personal injury or death.</p>

### Connecting the solar inverter to the aGate

When connecting a solar inverter to the aGate, the solar breaker is the only interface to be used. Do not connect the solar inverter to any other port.

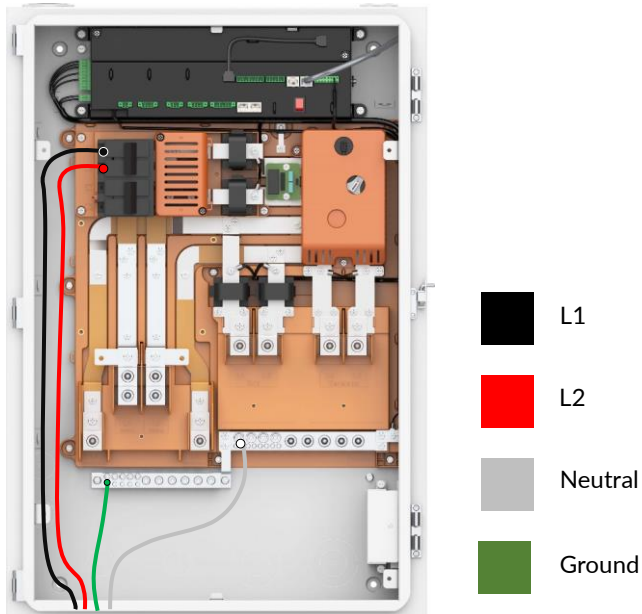

### Connecting the backup panel to the aGate

Connect the backup panel conductors to the aGate terminals. Refer to **Wiring requirements** for recommended cables.

After installation of the backup panel breaker, L1 and L2 will swap sides for connections (L2 is located to the left while L1 is to the right).

Without a backup panel breaker

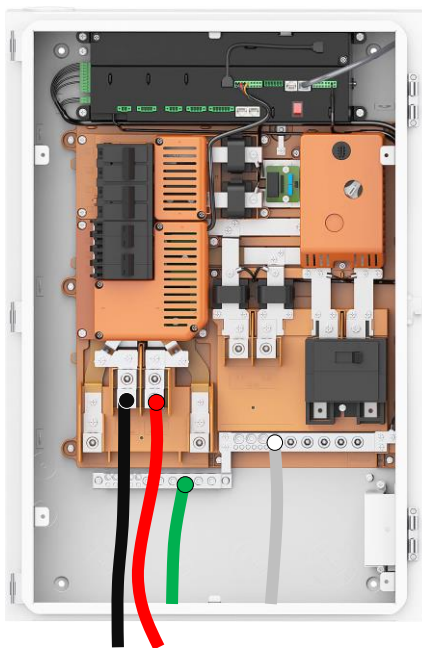

With a backup panel breaker

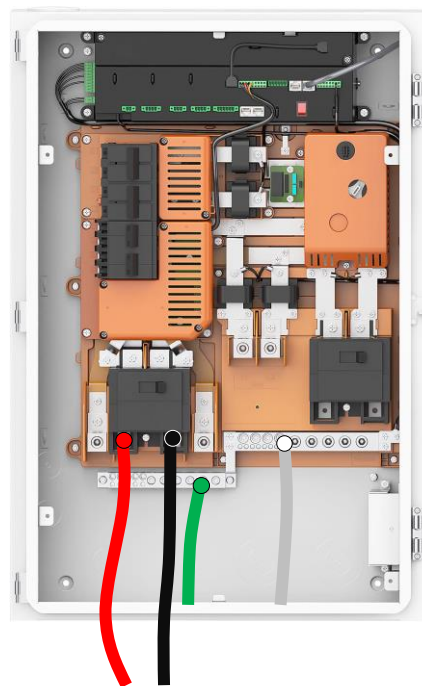

### Connecting the grid supply to the aGate

Connect the grid supply conductors to the aGate terminals. Refer to **Wiring requirements** for recommended cables.

After installation of the grid breaker, L1 and L2 will swap sides for connections (L2 is located to the left while L1 is to the right).

Without a grid breaker

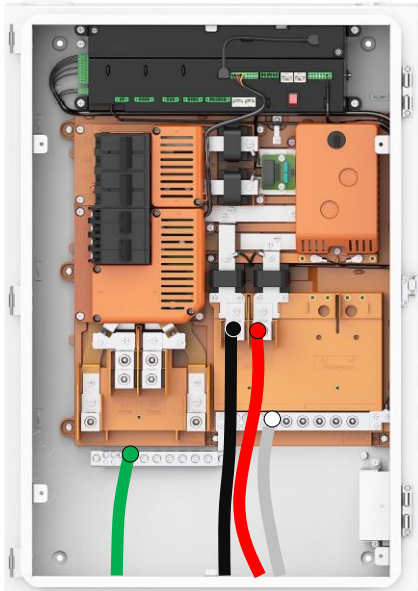

With a grid breaker

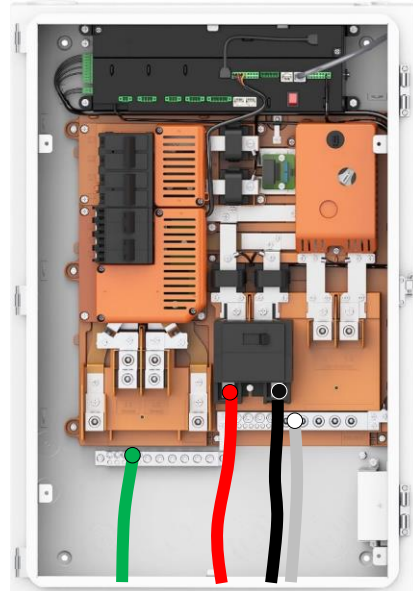

According to NFPA 70 250 Grounding and Bonding Part V, when installed as service equipment, the neutral and ground should be bonded together, as shown in the figure below.

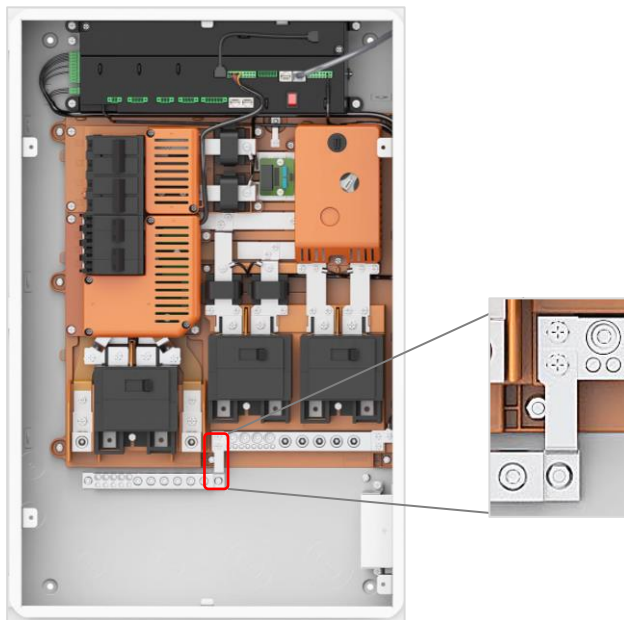

The Neutral-Ground Bonding Jumper must only be removed if not installed as Service Equipment, or for test purposes.

A torque wrench with 11/32" hex sockets will be needed to remove or install the bonding jumpers.

For installation, the required torque is 3 Nm (26.55 Lb-in.).



**WARNING:** To ensure safe operation in Backup Mode, the aGate must have a local ground connection, such as through a ground rod or ground electrode. The connection of the ground rod must comply with local codes and regulations.

## Connecting aPower(s) to the aGate

### Connecting a single aPower to the aGate

Follow the guidelines below when wiring a single aPower to the aGate:

- Use one (1) pair of wires for a single aPower connection to the aPower breaker on the aGate.
- The WAGO terminals of the aPower can only be connected using 10AWG power wire.
- The recommended strip length of the cable connected to the WAGO terminal is 0.47 to 0.55 (12 to 14 mm) inches.
- To connect the other end of the cable to the breaker, determine the cable stripping length based on the breaker configured.

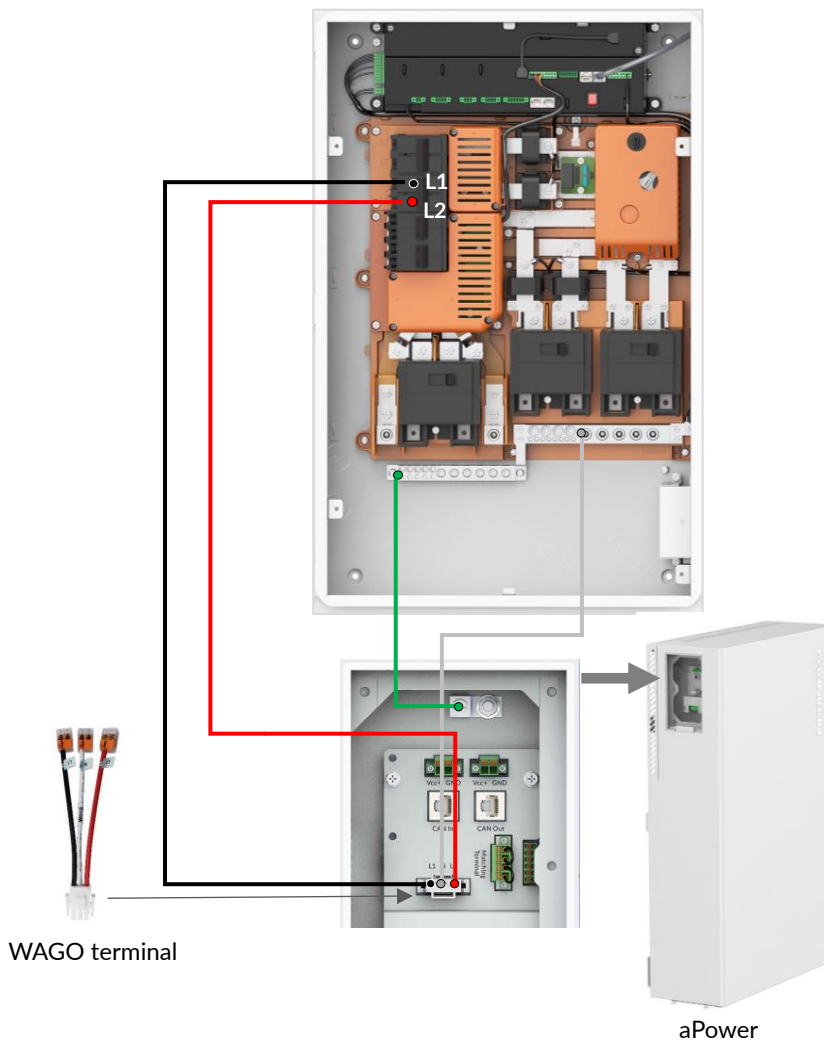

The cable stripping length:

0.47-0.55 in.



### Connecting 2-3 aPowers to the aGate

For 2 or 3 aPowers connection, an additional combiner box will be needed, and the power output cable from the combiner box should be connected to the aPower breaker in the aGate.

Each aPower is connected to the combiner box via a dedicated circuit breaker rated at 30 Amps.

Follow the image below to connect 2-3 aPowers to the aGate.

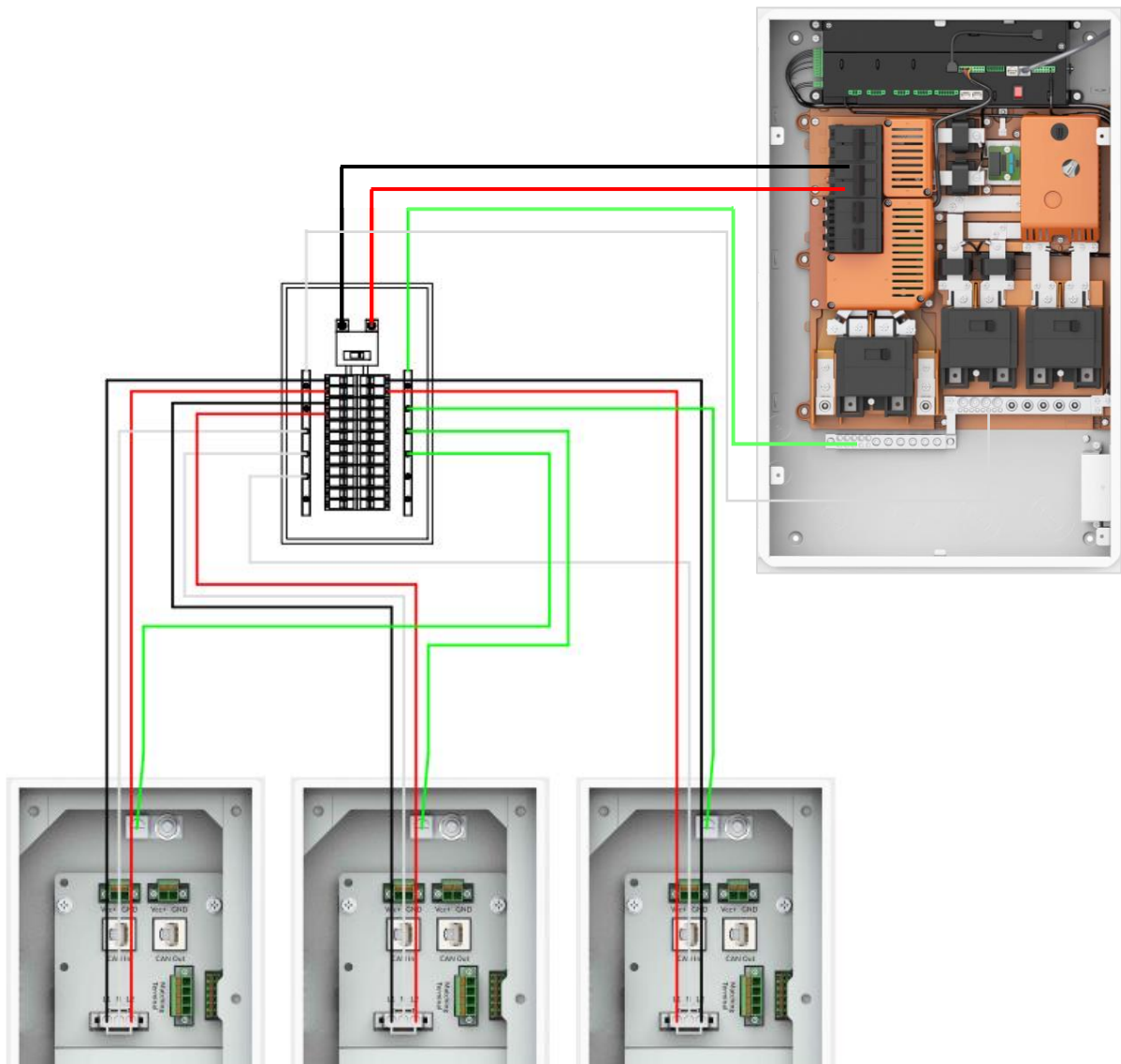

### Connecting more than 4 aPowers to the aGate

For more than 4 aPowers, consult with FranklinWH technical support.

The circuit breaker for the aPower port supports a maximum of 100 A. If the homeowner needs to connect a circuit breaker larger than 100 A, connect through the backup loads terminals on the aGate.

There are two sets of lugs on the aGate backup load terminals. When connecting more than four aPower units to the aGate, use one set for the aPower input and one for the backup main panel output.

In this scenario, the combiner box must have a main circuit breaker that connects to the aGate.

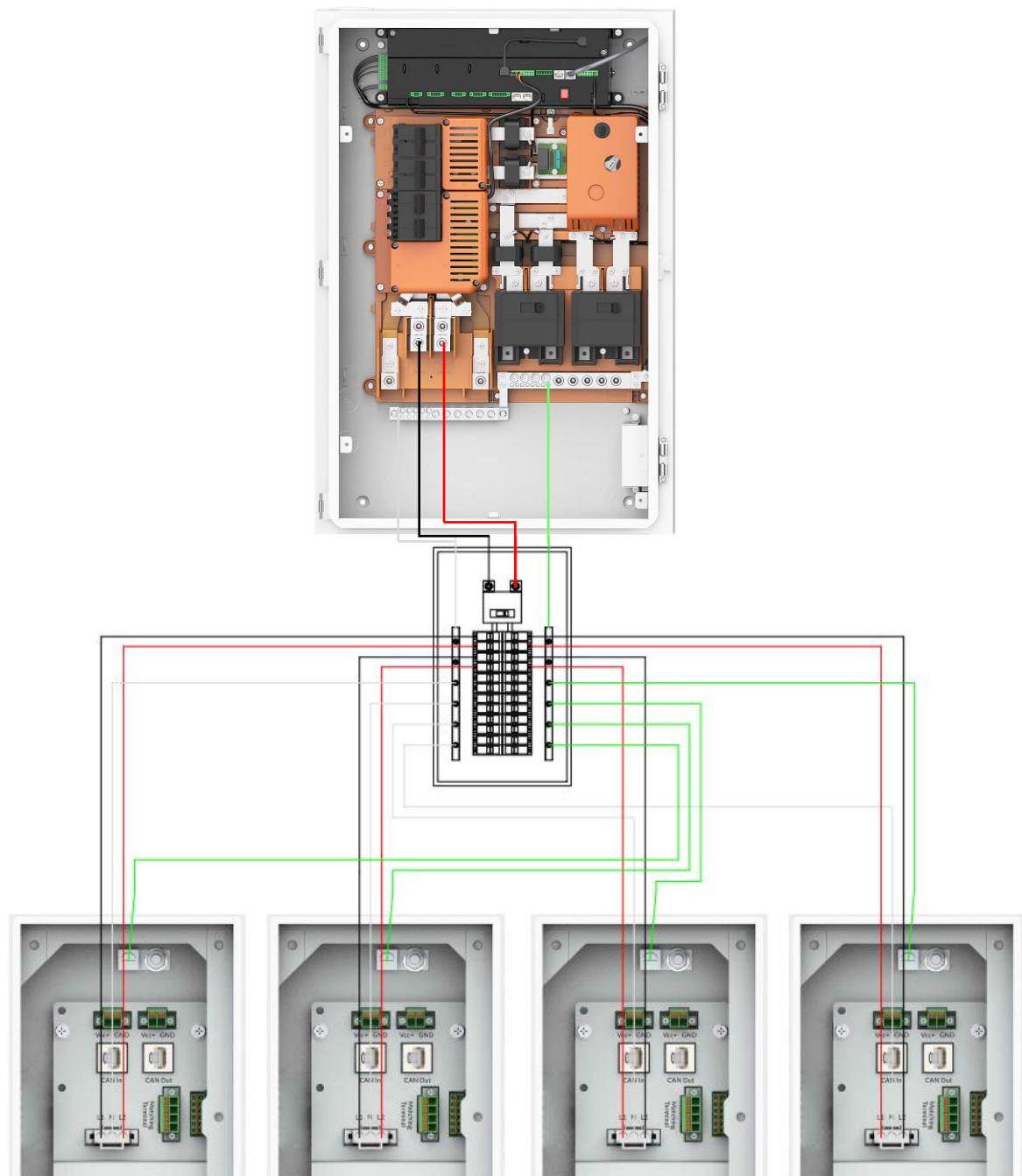

## Wiring

Terminal	Wire Gauge	Tool	Strip Length	Torque
Dual-lug Terminal	4 AWG-250 MCM CU/AL	8 mm hex wrench 5/8-18 UNF Hex screw	1 in. (upper) 2 in. (lower)	3/0 AWG-250 MCM 275 LB-IN 4 AWG-2/0 AWG 110 LB-IN
Single-lug Terminal	4 AWG-250 MCM CU/AL	8 mm hex wrench 5/8-18 UNF Hex screw	1 in	3/0 AWG-250 MCM 275LB-IN 4 AWG-2/0 AWG 110LB-IN
N bar	4 AWG-250 MCM CU/AL	8 mm hex wrench 5/8-18 UNF Hex screw	1 in	3/0 AWG-250 MCM 275 LB-IN 4 AWG-2/0 AWG 110 LB-IN
	14 AWG-2/0 AWG CU/AL	5 mm hex wrench 7/16-20 UNF Hex screw	1 in.	3 AWG-2/0 AWG 110 LB-IN 14 AWG-4 AWG 35 LB-IN
	14 AWG-4 AWG CU/AL	Straight screwdriver 1/4-28 UNF	0.6 in.	14 AWG-4 AWG 26 LB-IN
G bar	14 AWG-2/0 AWG CU/AL	5mm hex wrench Hex screw: 7/16-20 UNF	0.8 in.	3 AWG-2/0 AWG 110 LB-IN 14 AWG-4 AWG 35 LB-IN
	14 AWG-4 AWG CU/AL	Straight screwdriver 1/4-28 UNF	0.4 in./0.8 in.	14 AWG-4 AWG 26 LB-IN

## Install Optional Emergency Power Off (EPO) Switch

When an emergency situation occurs, such as fire or a smoking battery, the user may manually press the EPO switch button to power off the entire system, where it is safe to do so. The external EPO switch is optional. Consult your local AHJ or Utility before installation.



**NOTE:** If the external EPO switch is not connected to the FHP system, please keep the factory default configuration i.e., the factory-installed EPO terminal block connector on the EMS is short connected as shown in the figure to the right.



### Guidelines for EPO switch selection and installation:

- Must be labeled as "Emergency Stop Button," "Emergency Stop Device," "Emergency Stop Unit."
- Must have an ON/OFF switch that maintains its position after being manually set to either status.
- Must have a clear indication of the ON/OFF positions.
- Must be outdoor rated (NEMA 3R or higher).
- The maximum low voltage wire running between the EPO switch and the aGate should not exceed 150 feet (45.3 m).
- The EPO shall have a rated voltage of 5 V or higher.

### Installation Procedures

- 1) Make sure all breakers in the aGate and all switches connected to the aGate are disconnected. Wait at least five (5) minutes. Use a multimeter to check that the AC voltages at both input and output terminals of the aGate are zero (0), to ensure that all electrical equipment has been disconnected from the aGate.



**WARNING:** When the EPO button is pressed, the EPO is in the OFF state. That means the EPO function has been activated to protect the system. At this time, the aPower(s) will be shut off and all relays inside aGate (including the supply relay, the generator relay, the Smart Circuits relay, and the solar relay) will be disconnected. It also disconnects the utility grid and the backup port on aGate. Auxiliary power remains ON.

Do not use the EPO for maintenance operations or in any condition other than an emergency.

- 2) Remove the factory-installed jumper from the EPO terminal block connector on the EMS module.



- Using wire rated at 16-24 AWG, connect pins 3 and 4 (labeled EPO) to the C (common) and NC (normal close) of an external EPO switch.

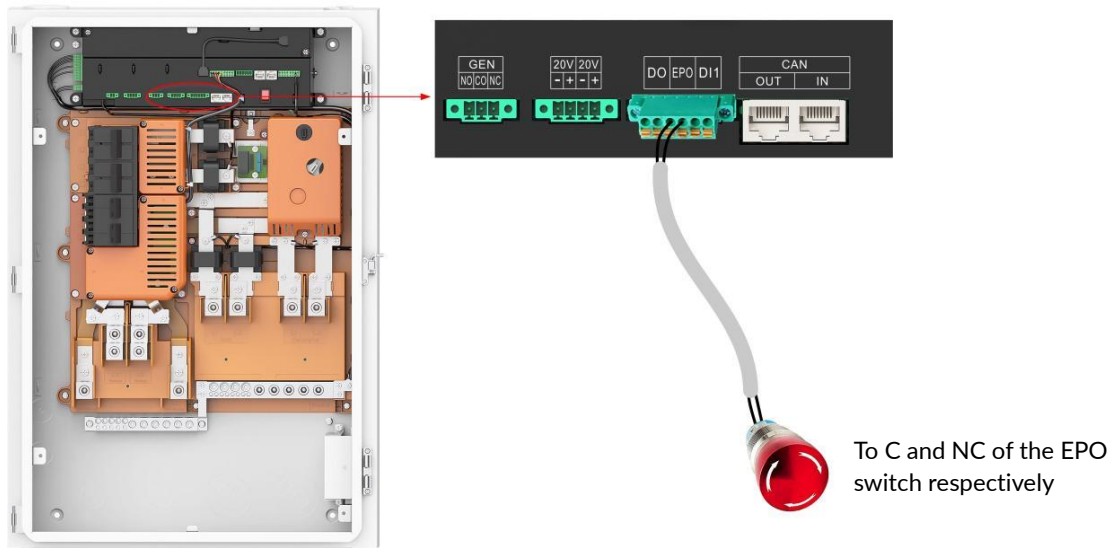

- Stick "Note of EPO" label from the aGate accessory bag on the aGate inner panel.

## Completing Installation

### Re-Install the aPower Wiring Compartment Cover and Install Grilles

- ① Put the WAGO terminals and cables in the wiring compartment upwards, as shown in the figure

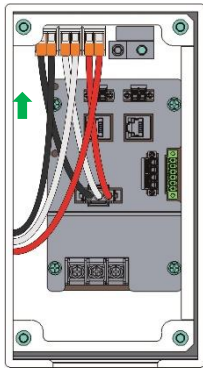

- ② Install the internal cover for the wiring compartment. Please check to make sure the cover label's S/N corresponds with the equipment

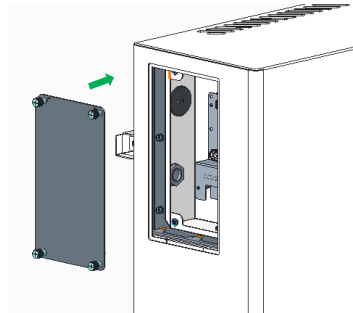

**WARNING:** Make sure the stripping length of cable is appropriate, the conductors are firmly secured, and there are no exposed conductors.

- ③ Tighten the four screws by turning clockwise using a #3 x 4" Phillips head screwdriver.

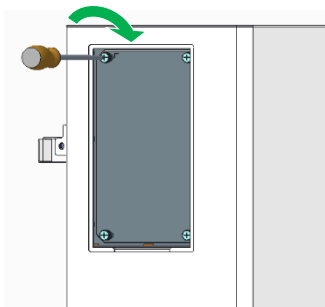

- ④ Install the external panel.

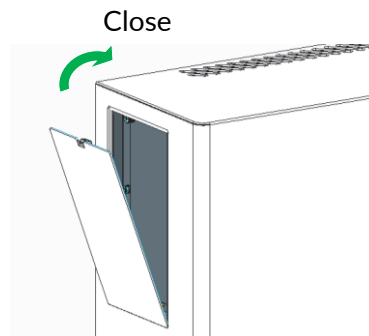

- ⑤ Use a diagonal cutting pliers to remove the knockout holes on the grille. (Remove the knockout holes in the corresponding positions according to the installation directions of the pull box, wiring and conduit).



- ⑥ Install the three grilles.

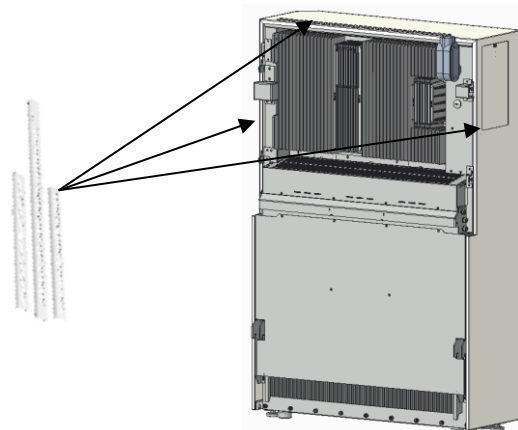

### Re-Install the aGate Door and Inner Panel

- 1) Re-install the aGate door.
- 2) Remove the knockouts on the inner panel according to the installed breakers.



- 3) Install the inner panel and fasten it by tightening the four original M5 x 12 combination bolts to 2.21 lbf-ft (3.0 Nm).
- 4) Stick the labels from the literature kit (bag with labels and accessories) on the aGate inner panel to indicate circuits.
- 5) Close the aGate door. Press the upper and lower latches to ensure that the door is tightly closed without any gaps.



**WARNING:** Gaps between the door and enclosure may cause water leaking into the aGate.

## Commissioning and Acceptance

The FHP system installation is complete. For the commissioning and acceptance process, please refer to the [Franklin Home Power Commissioning Guide](#).

### Appendix 1: Allowed Breakers

Table 1 Grid Breaker

Grid Breaker			
S/N	Model	Current	Description
1	CSR2100	100 A	Eaton#Circuit Breaker; 2-Pole, 25 kAIC, 100 A/240 V
2	CSR2125N	125 A	Eaton#Circuit Breaker; 2-Pole, 25 kAIC, 125 A/240 V
3	CSR2150N	150 A	Eaton#Circuit Breaker; 2-Pole, 25 kAIC, 150 A/240 V
4	CSR2175N	175 A	Eaton#Circuit Breaker; 2-Pole, 25 kAIC, 175 A/240 V
5	CSR2200N	200 A	Eaton#Circuit Breaker; 2-Pole, 25 kAIC, 200 A/240 V
6	BW2100	100 A	Eaton#Circuit Breaker; 2-Pole, 10 kAIC, 100 A/240 V
7	BW2125	125 A	Eaton#Circuit Breaker; 2-Pole, 10 kAIC, 125 A/240 V
8	BW2150	150 A	Eaton#Circuit Breaker; 2-Pole, 10 kAIC, 150 A/240 V
9	BW2175	175 A	Eaton#Circuit Breaker; 2-Pole, 10 kAIC, 175 A/240 V
10	BW2200	200 A	Eaton#Circuit Breaker; 2-Pole, 10 kAIC, 200 A/240 V
11	BWH2100N	100 A	Eaton#Circuit Breaker; 2-Pole, 25 kAIC, 100 A/240 V
12	BWH2125N	125 A	Eaton#Circuit Breaker; 2-Pole, 25 kAIC, 125 A/240 V
13	BWH2150N	150 A	Eaton#Circuit Breaker; 2-Pole, 25 kAIC, 150 A/240 V
14	BWH2175N	175 A	Eaton#Circuit Breaker; 2-Pole, 25 kAIC, 175 A/240 V
15	BWH2200N	200 A	Eaton#Circuit Breaker; 2-Pole, 25 kAIC, 200 A/240 V

Table 2 Backup Panel Breaker

Backup Panel Breaker			
S/N	Model	Current	Description
1	CSR2100	100 A	Eaton#Circuit Breaker; 2-Pole, 25 kAIC, 100 A/240 V
2	CSR2125N	125 A	Eaton#Circuit Breaker; 2-Pole, 25 kAIC, 125 A/240 V
3	CSR2150N	150 A	Eaton#Circuit Breaker; 2-Pole, 25 kAIC, 150 A/240 V
4	CSR2175N	175 A	Eaton#Circuit Breaker; 2-Pole, 25 kAIC, 175 A/240 V
5	CSR2200N	200 A	Eaton#Circuit Breaker; 2-Pole, 25 kAIC, 200 A/240 V
6	BW2100	100 A	Eaton#Circuit Breaker; 2-Pole, 10 kAIC, 100 A/240 V
7	BW2125	125 A	Eaton#Circuit Breaker; 2-Pole, 10 kAIC, 125 A/240 V
8	BW2150	150 A	Eaton#Circuit Breaker; 2-Pole, 10 kAIC, 150 A/240 V
9	BW2175	175 A	Eaton#Circuit Breaker; 2-Pole, 10 kAIC, 175 A/240 V
10	BW2200	200 A	Eaton#Circuit Breaker; 2-Pole, 10 kAIC, 200 A/240 V
11	BWH2100N	100 A	Eaton#Circuit Breaker; 2-Pole, 25 kAIC, 100 A/240 V
12	BWH2125N	125 A	Eaton#Circuit Breaker; 2-Pole, 25 kAIC, 125 A/240 V
13	BWH2150N	150 A	Eaton#Circuit Breaker; 2-Pole, 25 kAIC, 150 A/240 V
14	BWH2175N	175 A	Eaton#Circuit Breaker; 2-Pole, 25 kAIC, 175 A/240 V
15	BWH2200N	200 A	Eaton#Circuit Breaker; 2-Pole, 25 kAIC, 200 A/240 V

Table 3 Generator Breaker

Generator Breaker			
S/N	Model	Current	Description
1	CSR2100	100 A	Eaton#Circuit Breaker; 2-Pole, 25 kAIC, 100 A/240 V
2	CSR2125N	125 A	Eaton#Circuit Breaker; 2-Pole, 25 kAIC, 125 A/240 V
3	CSR2150N	150 A	Eaton#Circuit Breaker; 2-Pole, 25 kAIC, 150 A/240 V
4	CSR2175N	175 A	Eaton#Circuit Breaker; 2-Pole, 25 kAIC, 175 A/240 V
5	CSR2200N	200 A	Eaton#Circuit Breaker; 2-Pole, 25 kAIC, 200 A/240 V

6	BW2100	100 A	Eaton#Circuit Breaker; 2-Pole, 10 kAIC, 100 A/240 V
7	BW2125	125 A	Eaton#Circuit Breaker; 2-Pole, 10 kAIC, 125 A/240 V
8	BW2150	150 A	Eaton#Circuit Breaker; 2-Pole, 10 kAIC, 150 A/240 V
9	BW2175	175 A	Eaton#Circuit Breaker; 2-Pole, 10 kAIC, 175 A/240 V
10	BW2200	200 A	Eaton#Circuit Breaker; 2-Pole, 10 kAIC, 200 A/240 V
11	BWH2100N	100 A	Eaton#Circuit Breaker; 2-Pole, 25 kAIC, 100 A/240 V
12	BWH2125N	125 A	Eaton#Circuit Breaker; 2-Pole, 25 kAIC, 125 A/240 V
13	BWH2150N	150 A	Eaton#Circuit Breaker; 2-Pole, 25 kAIC, 150 A/240 V
14	BWH2175N	175 A	Eaton#Circuit Breaker; 2-Pole, 25 kAIC, 175 A/240 V
15	BWH2200N	200 A	Eaton#Circuit Breaker; 2-Pole, 25 kAIC, 200 A/240 V

Table 4 Solar Breaker

Solar Breaker				
S/N	Description	Manufacturer Model 1	Manufacturer Model 2	Manufacturer Model 3
1	2-Pole, 10 kAIC, 30 A/240 V	Eaton# BR230	Siemens# Q230	Schneider# HOM230
2	2-Pole, 10 kAIC, 40 A/240 V	Eaton# BR240	Siemens# Q240	Schneider# HOM240
3	2-Pole, 10 kAIC, 50 A/240 V	Eaton# BR250	Siemens# Q250	Schneider# HOM250
4	2-Pole, 10 kAIC, 60 A/240 V	Eaton# BR260	Siemens# Q260	Schneider# HOM260
5	2-Pole, 10 kAIC, 70 A/240 V	Eaton# BR270	Siemens# Q270	Schneider# HOM270
6	2-Pole, 10 kAIC, 80 A/240 V	Eaton# BR280	Siemens# Q280	Schneider# HOM280
7	2-Pole, 22 kAIC, 30 A/240 V	Eaton# BRH230	Siemens# Q230H	N/A
8	2-Pole, 22 kAIC, 40 A/240 V	Eaton# BRH240	Siemens# Q240H	N/A
9	2-Pole, 22 kAIC, 50 A/240 V	Eaton# BRH250	Siemens# Q250H	N/A
10	2-Pole, 22 kAIC, 60 A/240 V	Eaton# BRH260	Siemens# Q260H	N/A
11	2-Pole, 22 kAIC, 70 A/240 V	Eaton# BRH270	Siemens# Q270H	N/A
12	2-Pole, 22 kAIC, 80 A/240 V	Eaton# BRH280	Siemens# Q280H	N/A

Table 5 aPower Breaker

aPower Breaker				
S/N	Description	Manufacturer Model 1	Manufacturer Model 2	Manufacturer Model 3
1	2-Pole, 10 kAIC, 40 A/240 V	Eaton# BR240	Siemens# Q240	Schneider# HOM240
2	2-Pole, 10 kAIC, 50 A/240 V	Eaton# BR250	Siemens# Q250	Schneider# HOM250
3	2-Pole, 10 kAIC, 60 A/240 V	Eaton# BR260	Siemens# Q260	Schneider# HOM260
4	2-Pole, 10 kAIC, 70 A/240 V	Eaton# BR270	Siemens# Q270	Schneider# HOM270
5	2-Pole, 10 kAIC, 80 A/240 V	Eaton# BR280	Siemens# Q280	Schneider# HOM280
6	2-Pole, 10 kAIC, 90 A/240 V	Eaton# BR290	Siemens# Q290	Schneider# HOM290
7	2-Pole, 10 kAIC, 100 A/240 V	Eaton# BR2100	Siemens# Q2100	Schneider# HOM2100
8	2-Pole, 22 kAIC, 30 A/240 V	Eaton# BRH230	Siemens# Q230H	N/A
9	2-Pole, 22 kAIC, 40 A/240 V	Eaton# BRH240	Siemens# Q240H	N/A
10	2-Pole, 22 kAIC, 50 A/240 V	Eaton# BRH250	Siemens# Q250H	N/A
11	2-Pole, 22 kAIC, 60 A/240 V	Eaton# BRH260	Siemens# Q260H	N/A
12	2-Pole, 22 kAIC, 70 A/240 V	Eaton# BRH270	Siemens# Q270H	N/A
13	2-Pole, 22 kAIC, 80 A/240 V	Eaton# BRH280	Siemens# Q280H	N/A
14	2-Pole, 22 kAIC, 90 A/240 V	Eaton# BRH290	Siemens# Q290H	N/A
15	2-Pole, 22 kAIC, 100 A/240 V	Eaton# BRH2100	Siemens# Q2100H	N/A

Table 6 Smart Circuits Breaker

Breaker for Smart Circuit 1 and 2 (1-Pole)			
S/N	Model	Current	Description
1	CH120	20 A	Eaton#Circuit Breaker; 1-Pole, 10 kAIC, 20 A/240 V
2	CH130	30 A	Eaton#Circuit Breaker; 1-Pole, 10 kAIC, 30 A/240 V
3	CH135	35 A	Eaton#Circuit Breaker; 1-Pole, 10 kAIC, 35 A/240 V
4	CH140	40 A	Eaton#Circuit Breaker; 1-Pole, 10 kAIC, 40 A/240 V
5	CH145	45 A	Eaton#Circuit Breaker; 1-Pole, 10 kAIC, 45 A/240 V
6	CH150	50 A	Eaton#Circuit Breaker; 1-Pole, 10 kAIC, 50 A/240 V
7	CHF130	30 A	Eaton#Circuit Breaker; 1-Pole, 10 kAIC, 30 A/240 V

8	CHF135	35 A	Eaton#Circuit Breaker; 1-Pole, 10 kAIC, 35 A/240 V
9	CHF140	40 A	Eaton#Circuit Breaker; 1-Pole, 10 kAIC, 40 A/240 V
10	CHF145	45 A	Eaton#Circuit Breaker; 1-Pole, 10 kAIC, 45 A/240 V
11	CHF150	50 A	Eaton # Circuit Breaker; 1-Pole, 10 kAIC, 50 A/240 V
<b>Breaker for Smart Circuit 1 + Circuit 2 (2-Pole)</b>			
S/N	Model	Current	Description
1	CH230	30 A	Eaton#Circuit Breaker; 2-Pole, 10 kAIC, 30 A/240 V
2	CH235	35 A	Eaton#Circuit Breaker; 2-Pole, 10 kAIC, 35 A/240 V
3	CH240	40 A	Eaton#Circuit Breaker; 2-Pole, 10 kAIC, 40 A/240 V
4	CH245	45 A	Eaton#Circuit Breaker; 2-Pole, 10 kAIC, 45 A/240 V
5	CH250	50 A	Eaton#Circuit Breaker; 2-Pole, 10 kAIC, 50 A/240 V
6	CHF230	30 A	Eaton#Circuit Breaker; 2-Pole, 10 kAIC, 30 A/240 V
7	CHF235	35 A	Eaton#Circuit Breaker; 2-Pole, 10 kAIC, 35 A/240 V
8	CHF240	40 A	Eaton#Circuit Breaker; 2-Pole, 10 kAIC, 40 A/240 V
9	CHF245	45 A	Eaton#Circuit Breaker; 2-Pole, 10 kAIC, 45 A/240 V
10	CHF250	50 A	Eaton#Circuit Breaker; 2-Pole, 10 kAIC, 50 A/240 V
<b>Breaker for Smart Circuit 3</b>			
S/N	Model	Current	Description
1	CH230	30 A	Eaton#Circuit Breaker; 2-Pole, 10 kAIC, 30 A/240 V
2	CH235	35 A	Eaton#Circuit Breaker; 2-Pole, 10 kAIC, 35 A/240 V
3	CH240	40 A	Eaton#Circuit Breaker; 2-Pole, 10 kAIC, 40 A/240 V
4	CH245	45 A	Eaton#Circuit Breaker; 2-Pole, 10 kAIC, 45 A/240 V
5	CH250	50 A	Eaton#Circuit Breaker; 2-Pole, 10 kAIC, 50 A/240 V
6	CH260	60 A	Eaton#Circuit Breaker; 2-Pole, 10 kAIC, 60 A/240 V
7	CH270	70 A	Eaton#Circuit Breaker; 2-Pole, 10 kAIC, 70 A/240 V
8	CH280	80 A	Eaton#Circuit Breaker; 2-Pole, 10 kAIC, 80 A/240 V
9	CHF230	30 A	Eaton#Circuit Breaker; 2-Pole, 10 kAIC, 30 A/240 V
10	CHF235	35 A	Eaton#Circuit Breaker; 2-Pole, 10 kAIC, 35 A/240 V
11	CHF240	40 A	Eaton#Circuit Breaker; 2-Pole, 10 kAIC, 40 A/240 V
12	CHF245	45 A	Eaton#Circuit Breaker; 2-Pole, 10 kAIC, 45 A/240 V
13	CHF250	50 A	Eaton#Circuit Breaker; 2-Pole, 10 kAIC, 50 A/240 V

Table 7 Breaker in a combiner box

S/N	Max. Current	Description
1	30 A	Circuit Breaker; 2-Pole, 10 kAIC, 30 A/240 V
2	30 A	Circuit Breaker; 2-Pole, 22 kAIC, 30 A/240 V

## Appendix 2: NFPA 70 (National Electrical Code, “NEC”) AC Disconnect Labeling Requirements

The FranklinWH aPower, as a grid-interactive Battery Energy Storage System, must have an approved AC disconnecting means. The AC disconnect is required to have a label which includes the information in the table below.

2017 NEC 706.7(D) ESS Disconnecting Means labeling requirements	Associated Value	2020 NEC 706.15(C) ESS Disconnecting Means labeling requirements	Associated Value
Nominal ESS voltage	240 VAC	Nominal ESS AC voltage and maximum ESS DC voltage	240 VAC, 57.6 VDC
Maximum available short-circuit current derived from the ESS	60 A, AC	Available fault current derived from the ESS	42 A, AC
The associated clearing time or arc duration based on the available short-circuit current from the ESS and associated overcurrent protective devices if applicable	50 ms	An arc-flash label applied in accordance with acceptable industry practice	Standard arc flash label
Date the calculation was performed	Installers fill this in	Date the calculation was performed	Installers fill this in

## Appendix 3: Datasheet

### aPower

BAT DC Terminal, Bi-Directional:	
Nominal voltage (V)	51.2 V
Max. charging current (A)	100 A
Max. charging power (kW)	5.0 kW
Max. discharging current (A)	118 A
Max. discharging power (kW)	5.3 kW
AC terminal, Bi-Directional:	
Nominal AC voltage (V)	120/240 V, (L1, L2, N)
Nominal AC frequency (Hz)	60 Hz
Nominal AC output current (A)	21 A
Nominal AC output power (kW), (L-N)	2.5 kW
Nominal AC output power (kW), (L-L)	5.0 kW
Max. Continuous AC output current (A)	24.5 A
Max. Continuous AC output power (kVA), (L-N)	2.9 kVA
Max. Continuous AC output power (kVA), (L-L)	5.8 kVA
Nominal AC input current (A)	21 A
Max. Continuous AC input current (A)	24.5 A
Nominal AC input power (kW), (L-L)	5.0 kW
Max. Continuous AC input power (kVA), (L-L)	5.8 kVA

Power Factor Range	0.85 leading to 0.85 lagging
Max. overcurrent protection (amps), circuit breaker ratings	30 A
<b>Others</b>	
Operation temperature range	-4°F to 122°F (-20°C to +50°C)
Storage temperature range	≤24 hours: -22°F to 140°F (-30°C to +60°C) ≤ 9 months: -4°F to 113°F (-20°C to +45°C) ≤ 12 months: -4°F to 95°F (-20°C to +35°C)
Ingress protection	IP67 (Battery Pack & Inverter) IP56 (Wiring)
Operating Humidity (RH)	Up to 100 %, non-condensing
Storage Humidity (RH)	Up to 100 %, non-condensing
Certificate	UL9540, UL1973, UL9540A, UN38.3, UL1741 SB, UL1741 SA, IEEE1547, IEEE1547.1, FCC Part 15 Class B
Dimensions (W*H*D, inch)	29.5 in. x 45.3 in. x 11.4 in. (750 mm x 1150 mm x 290 mm)
Weight	395 lbs. (179 kg)

## aGate

<b>(1) Grid Terminal, Bi-Directional:</b>	
Nominal AC Grid voltage (V)	120/240 V, (L1, L2, N)
Nominal AC Grid frequency (Hz)	60 Hz
Nominal AC input current (A)	160 A
Nominal AC input power (kW)	38.4 kW
Max. Continuous AC input power (kVA)	38.4 kVA
Max. overcurrent protection (amps), circuit breaker ratings	200 A
<b>(2) Generator Terminal:</b>	
Nominal AC input voltage (V)	120/240 V, (L1, L2, N)
Nominal AC input frequency (Hz)	60 Hz
Nominal AC input current (A)	160 A
Nominal AC input power (kW)	38.4 kW
Max. Continuous AC input current (A)	160 A
Max. Continuous AC input power (kVA)	38.4 kVA
Max. overcurrent protection (amps), circuit breaker ratings	200 A
<b>(3) Non-Backup Output Terminal:</b>	
Nominal AC output voltage (V)	120/240 V, (L1, L2, N)
Nominal AC output frequency (Hz)	60 Hz
Nominal AC output current (A)	160 A
Nominal AC output power (kW)	38.4 kW
Max. Continuous AC output current (A)	160 A
Max. Continuous AC output power (kVA)	38.4 kVA
<b>(4) Backup Output Terminal:</b>	
Nominal AC output voltage (V)	120/240 V, (L1, L2, N)
Nominal AC output frequency (Hz)	60 Hz
Nominal AC output current (A)	160 A
Nominal AC output power (kW)	38.4 kW
Max. Continuous AC output current (A)	160 A
Max. Continuous AC output power (kVA)	38.4 kVA
<b>(5) Solar inverter's Input Terminal:</b>	
Nominal AC input voltage (V)	120/240 V, (L1, L2, N)
Nominal AC input frequency (Hz)	60 Hz
Nominal AC input current (A)	64 A
Nominal AC input power (kW)	15.36 kW
Max. overcurrent protection (amps), circuit breaker ratings	80 A
<b>(6) aPower AC terminal, Bi-Directional:</b>	
Nominal AC voltage (V)	120/240 V, (L1, L2, N)
Nominal AC frequency (Hz)	60 Hz
Nominal AC current (A)	80 A
Max. overcurrent protection (amps), circuit breaker ratings	100A
<b>(7) AC Output Terminal, Smart Circuit 1, 2:</b>	
Nominal AC output voltage (V)	120/240 V, (L1, L2, N)
Nominal AC output frequency (Hz)	60 Hz
Nominal AC output current (A)	40 A

Nominal AC output power (kW) (L-L)	9.6 kW
Max. Continuous AC output current (A) (L-L)	40 A
Max. Continuous AC output power (kW) (L-L)	9.6 kW
Nominal AC output power (kW) (L-N)	4.8 kW
Max. Continuous AC output current (A) (L-N)	40 A
Max. Continuous AC output power (kW) (L-N)	4.8 kW
Max. output overcurrent protection (amps), circuit breaker ratings	50 A
<b>(8) AC Output Terminal, Smart Circuit 3:</b>	
Nominal AC output voltage (V)	240 V, (L1, L2)
Nominal AC output frequency (Hz)	60 Hz
Nominal AC output current (A)	64 A
Nominal AC output power (kW) (L-L)	15.36 kW
Max. Continuous AC output current (A) (L-L)	64 A
Max. Continuous AC output power (kVA) (L-L)	15.36 kVA
Nominal AC output power (kW) (L-N)	7.68 kW
Max. Continuous AC output current (A) (L-N)	64 A
Max. Continuous AC output power (kVA) (L-N)	7.68 kVA
Max. output overcurrent protection (amps), circuit breaker ratings	80 A
<b>(9) Busbar:</b>	
Max. AC current (A)	280 A
<b>Others:</b>	
Operation temperature range	-4 °F to 122 °F (-20 °C to +50 °C)
Storage temperature range	-22 °F to 140 °F (-30 °C to +60 °C)
Enclosure Type	Type 3R
Operating Humidity (RH)	Up to 100 %, non-condensing
Storage Humidity (RH)	Up to 100 %, non-condensing
Weight	51 lbs. (23 kg)
Dimensions (W*H*D, inch)	21.7 in. x 31.5 in. x 6.3 in. (550 mm x 800 mm x 160 mm)
Ingress protection	IP44
Certificate	UL1741, UL67*, UL869A*, UL916*, FCC Part 15 Class B

UL67\*, UL869A\*, UL916\* : Sections from these standards were used during the safety evaluation and included in the UL 1741 listing.